

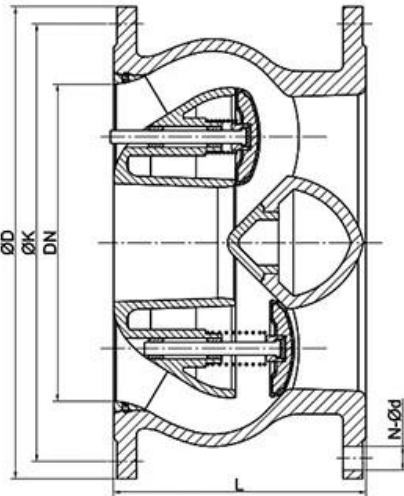

# DESIGN FEATURES

## Features

- 1.Streamlined: minimum noise
- 2.Anti-static design
- 3.Double Block & Bleed
- 4.Automatic Self-Venting Seats
- 5.Emergency Protection

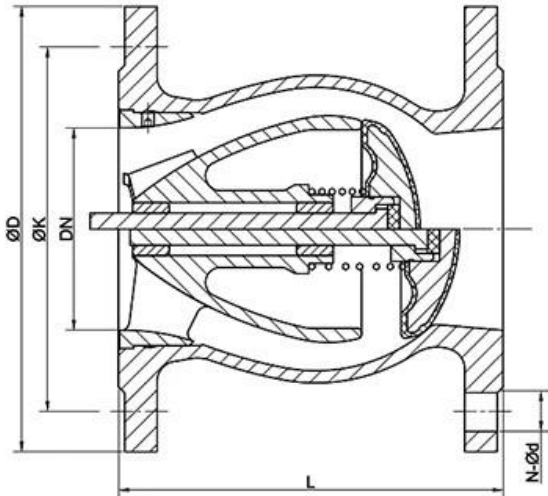

# APPLICATION SCENARIO



Industrial water application



Power plant



Sea water desalination



Water treatment



Water supply and drainage



HAVC



Food and drug



Water transport



# COMPANY INFORMATION

---



i 100% 100% 100% 100% 100%

ii CNC 100% 100% 100% 100% 100%

iii 100% 100% 100% 100% 100%

iv 100% 100% 100% 100% 100%

v GB 100% TUV CE ISO 9001 ADWO-2000 TS PED WRC WRAS KTW KTW API 6D API609

VI 100% / 100% / 100%

01

21 years of professional experience

03

Independent research and development team  
28 top senior professional researchers

05

100% high level ex-factory inspection

07

2 years quality assurance, repair and replacement

4 factories

02

2 professional testing centers

04

High quality imported materials

06

## COMPANY QUALIFICATION



## COMPANY EXHIBITION



□□□□□□□□□□□□□□□□  
□□□□□□□□□□□□□□□□

□□□□□□□□□□□□□□□□  
□□□□□□□hrdraulic□□□□□ RKSfluid□□□□□□□□□□□□□□□□

□□□□□□□□□□□□  
□□RKSfluid□□□□□□□□□□□□

□□□□□□□□  
□□□□□□□2□5□□□□□□□□□□□□□□□□□□□□

□□□  
□□□□□□□1□□

□□□□□□□□□□□□  
□□□□□100□□□□□□2□□□□□□□□□□□□□□□□  
□□□□□TUV□API□WRAS□CE□ISO□□□□  
□□□□□DIN□ASME□BS EN□JIS□API□AWWA□

□□□□□□□□□□□□□□□□□□□□  
□□RKSfluid□□20□□□□□□□70□□□□□□□□□□□□□□□□□□□□