



RKSfluid®

A key Valve in Flow Control



Butterfly Valve



Ball Valve



Gate Valve



Globe Valve



Check Valve



Pipe Fittings

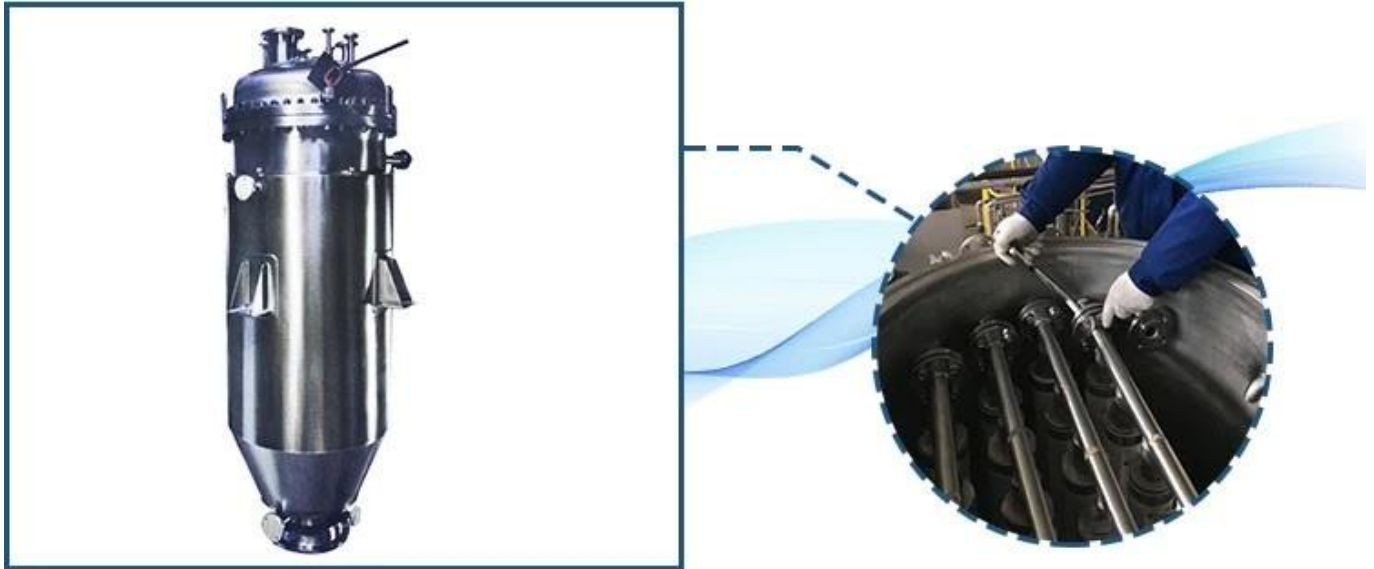

- Intelligent system, fully automatic sealing operation
- Seal zero leakage, unique structure easy for back flushing
- High efficiency by purified gas back washing
- High impurity content of filtration 0.1% ~ 50%
- Removable, porous wick, easy to replace, clean and maintain
- Designed for high production standard. Such as non-polluting food, biological products, medicine, fine chemistry, etc.

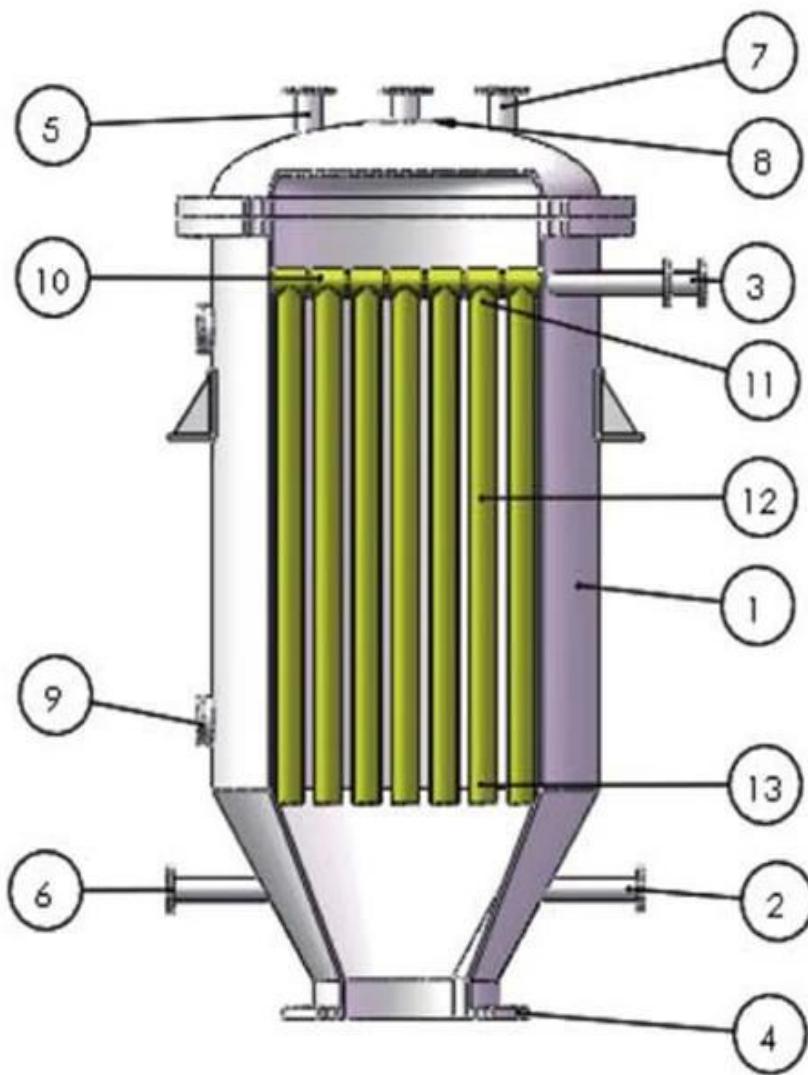

- 1, Pressure Vessel
- 2, Outlet
- 3, Outlet of clear liquid
- 4, Deslagging Port
- 5, Vent & Overflow port
- 6, Feed port
- 7, Connection port of instruments
- 8, Standby Port
- 9, Viewport
- 10, Liquid collection tube
- 11, Filtration unit
- 12, Filtration medium
- 13, Clamp for fixed the filter element

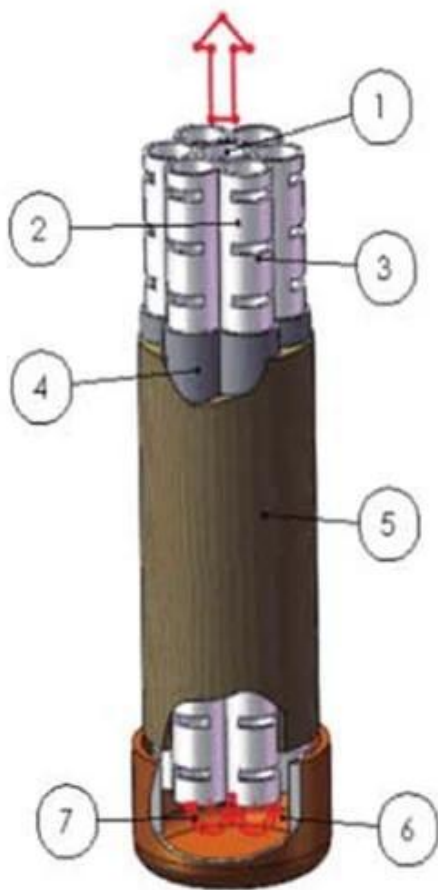

1. Central tube & Clear liquid collection tube
2. Filtration tube
3. A hole of filtration tube
4. Filtration medium
5. Filter cake
6. Collection chamber (connect the centre tube and filtration tube)
7. Clear liquid
8. Backflush gas

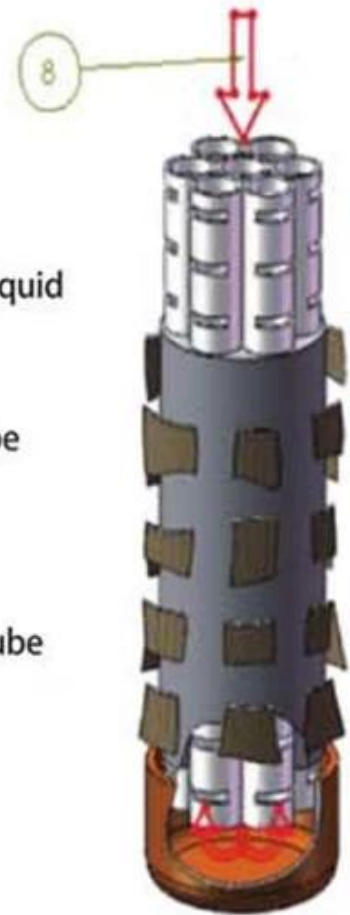

Our Factory



Company Advantages



1. 1. 21 years of professional experience
 2. 2. 4 factories
 3. 3. Independent research and development team
28 top senior professional researchers
4. 4. 2 professional testing centers
5. 5. 100% high level ex-factory inspection
6. 6. High quality imported materials
7. 7. 2 years quality assurance, repair and replacement

Q4

A4

Q5

A5

Q6

A6

Q7

A7