

DESIGN FEATURES

Features

- 1.Streamlined: minimum noise
- 2.Anti-static design
- 3.Double Block & Bleed
- 4.Automatic Self-Venting Seats
- 5.Emergency Protection

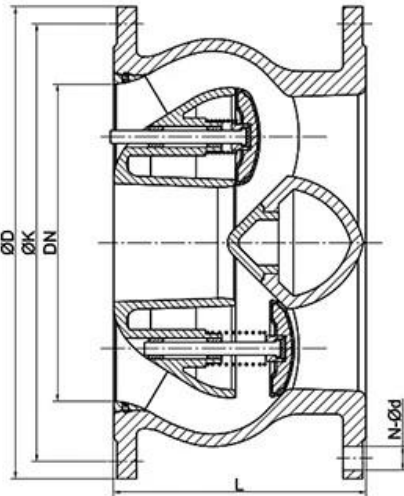
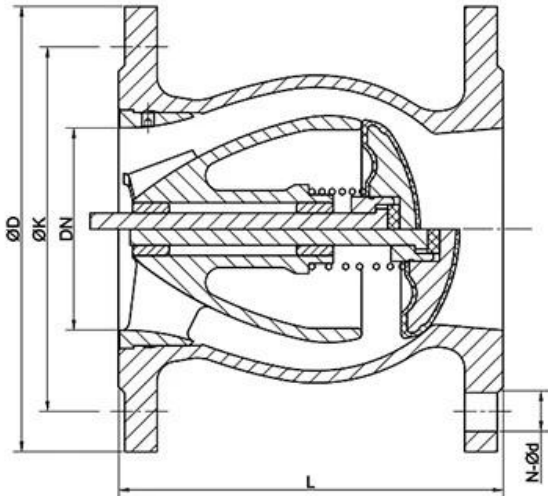

APPLICATION SCENARIO



Industrial water application



Power plant



Sea water desalination



Water treatment



Water supply and drainage



HAVC



Food and drug



Water transport



COMPANY INFORMATION



i 质量管理体系

ii CNC 质量管理体系

iii 质量管理体系

iv 质量管理体系

v GB 质量管理体系 TUV CE ISO 9001 ADWO-2000 TS PED WRC WRAS KTW KTW API 6D API609

VI 质量管理体系 / 体系 / 体系

01

21 years of professional experience

03

Independent research and development team
28 top senior professional researchers

05

100% high level ex-factory inspection

07

2 years quality assurance, repair and replacement

4 factories

02

2 professional testing centers

04

High quality imported materials

06

COMPANY QUALIFICATION



COMPANY EXHIBITION



