

RKSfluid®



RKSfluid®



RKSfluid®



DESIGN FEATURES

DURABLE

- No-pin connection, 1 pc blow-out proof stem
- DI/CI Nodularity over 95%

ANTI-CORROSION

- Material: Epoxy powder:  , Earth Best!
- Coating Thickness: 200-250µm
- Spraying temp: over 200°C. Doesn't fade, even wipe with diethyl ether

QUALITY STANDARD

- 100% quality test, follow DIN, ASTM, JIS, GB/T, ISO, BS EN, API
- ONLY ONE Manufacturer get CE certification up to DN1800
- 2 years warranty. 15000 times On-off test, 30000 times Destructive experiment



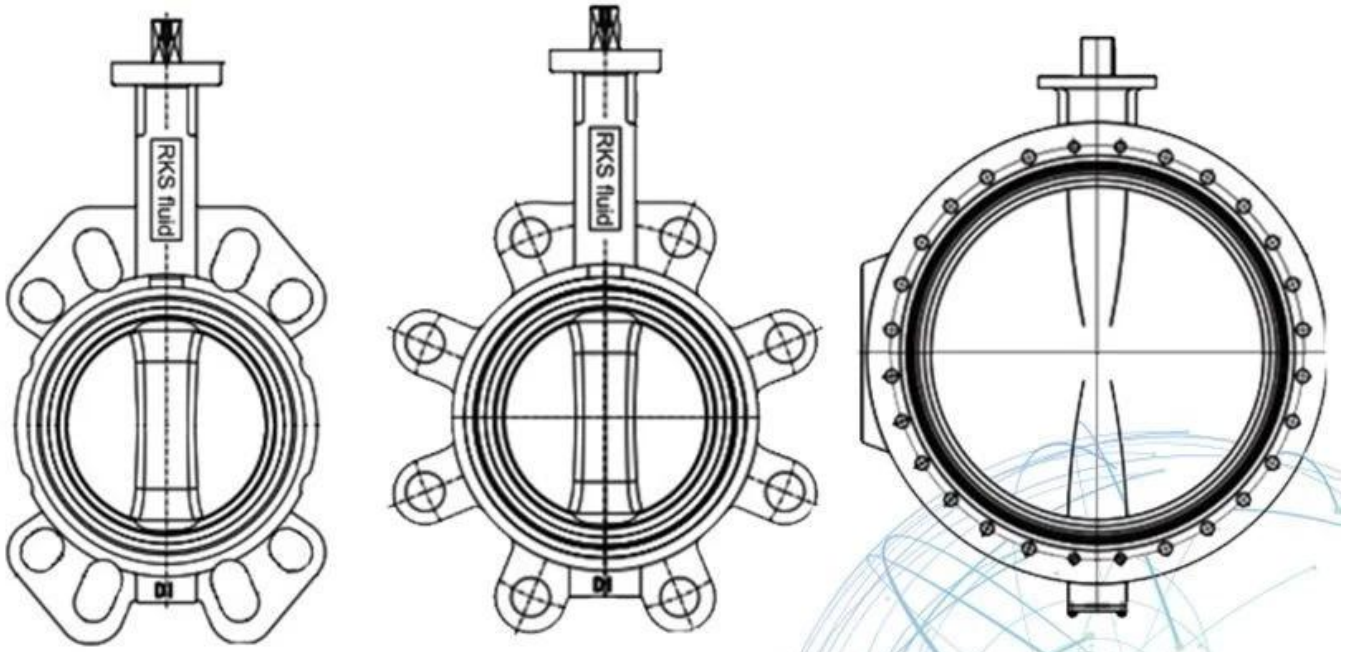

APPLICATION SCENARIO



Industrial water application



Power plant



Sea water desalination



Water treatment



Water supply and drainage



HAVC



Food and drug



Water transport



RKSfluid 1997
 1997
 1997
 1997

Il prodotto è conforme alle norme CE, GB, ISO 9001, TUV CE, ADWO-2000, TS, API, PED, WRC, WRAS, KTW, API 6D, API 609.

Il prodotto è conforme alle norme CE, GB, ISO 9001, TUV CE, ADWO-2000, TS, API, PED, WRC, WRAS, KTW, API 6D, API 609.

Il prodotto è conforme alle norme CE, GB, ISO 9001, TUV CE, ADWO-2000, TS, API, PED, WRC, WRAS, KTW, API 6D, API 609.

Il prodotto è conforme alle norme CE, GB, ISO 9001, TUV CE, ADWO-2000, TS, API, PED, WRC, WRAS, KTW, API 6D, API 609.

Il prodotto è conforme alle norme CE, GB, ISO 9001, TUV CE, ADWO-2000, TS, API, PED, WRC, WRAS, KTW, API 6D, API 609.

Il prodotto è conforme alle norme CE, GB, ISO 9001, TUV CE, ADWO-2000, TS, API, PED, WRC, WRAS, KTW, API 6D, API 609.

Our Factory





PTFE Butterfly Valve

BSEN 1092, DIN 2501, ANSI, JIS, AS2129

Size: DN50~DN600

Body: Ductile Iron

Disc: Ductile Iron+PTFE

Seat: PTFE

Connection: Wafer, Lug, Flange



PTFE Butterfly Valve

BSEN 1092, DIN 2501, ANSI, JIS, AS2129

Size: DN50~DN600

Body: Ductile Iron

Disc: Ductile Iron+PTFE

Seat: PTFE

Connection: Wafer, Lug, Flange



PTFE Butterfly Valve

BSEN 1092, DIN 2501, ANSI, JIS, AS2129

Size: DN50~DN600

Body: WCB, CF8, CF8M

Disc: CF8+PTFE, CF8M+PTFE

Seat: PTFE

Connection: Wafer, Lug



PTFE Butterfly Valve

BSEN 1092, DIN 2501, ANSI, JIS, AS2129

Size: DN50~DN600

Body: WCB, CF8, CF8M

Disc: CF8+PTFE, CF8M+PTFE

Seat: PTFE

Connection: Wafer, Lug



PTFE Butterfly Valve

BSEN 1092, DIN 2501, ANSI, JIS, AS2129

Size: DN50~DN600

Body: Ductile Iron

Disc: CF8, CF8M

Seat: PTFE

Connection: Wafer, Lug, Flange



PTFE Butterfly Valve

BSEN 1092, DIN 2501, ANSI, JIS, AS2129

Size: DN50~DN600

Body: WCB

Disc: CF8 +PTFE, CF8 +PFA

Seat: PTFE

Connection: Wafer, Lug, Flange



Resilient seat butterfly valve



Resilient seat butterfly valve



Resilient seat butterfly valve

PN10/PN16, ANSI 125LB/150LB,5K/10K

Size:DN25-DN2400

Body:DI CI

Disc: Stainless steel

Seat :EPDM, NBR, Viton

Connection: Wafer, Lug, Flange

PN10/PN16, ANSI 125LB/150LB,5K/10K

Size:DN25-DN2400

Body:DI CI

Disc: DI+ Nylon

Seat :EPDM, NBR, Viton

Connection: Wafer, Lug, Flange

PN10/PN16, ANSI 125LB/150LB,5K/10K

Size:DN25-DN2400

Body:DI CI

Disc: Stainless steel

Seat :EPDM, NBR, Viton

Connection: Wafer, Lug, Flange



Resilient seat butterfly valve



Double flange resilient seat butterfly valve



Short-neck butterfly valve for petroleum

PN10/PN16, ANSI 125LB/150LB,5K/10K

Size:DN25-DN2400

Body:DI CI

Disc: Stainless steel

Seat :EPDM, NBR, Viton

Connection: Wafer, Lug, Flange

PN10/PN16, ANSI 125LB/150LB, 5K/10K

Size:DN50-DN1000

Body:DI CI

Disc: Stainless steel

Seat :EPDM, NBR, Viton

Connection: Flange

ANSI 125LB/150LB

Top Flange Standard:ISO5211

Size:2"-12"

Body: DI CI

Disc :Stainless Steel

Seat : EPDM, NBR, Viton

Connection:Wafer, Lug

Our Certificates

