



# RKSfluid®

A key Valve in Flow Control



Butterfly Valve



Ball Valve



Gate Valve



Globe Valve



Check Valve



Pipe Fittings

## DESIGN FEATURES

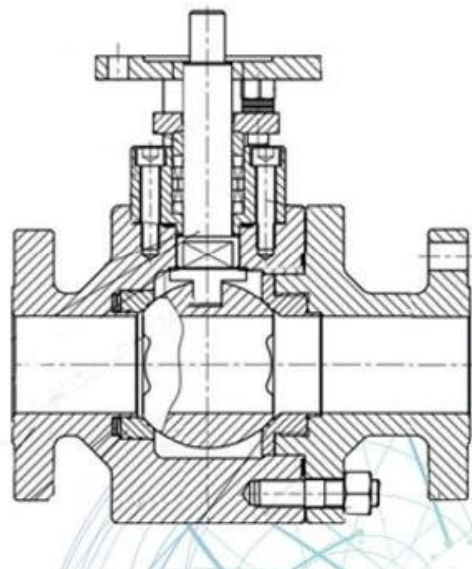
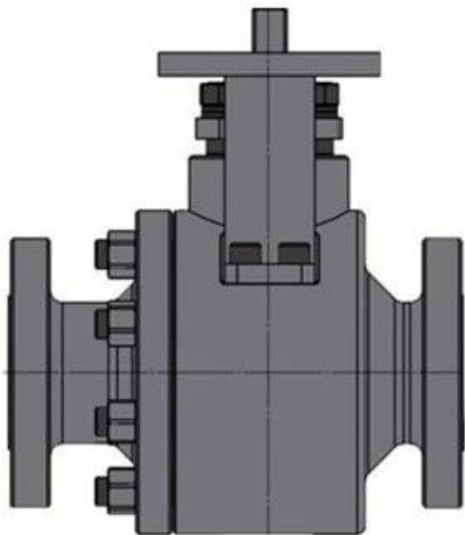
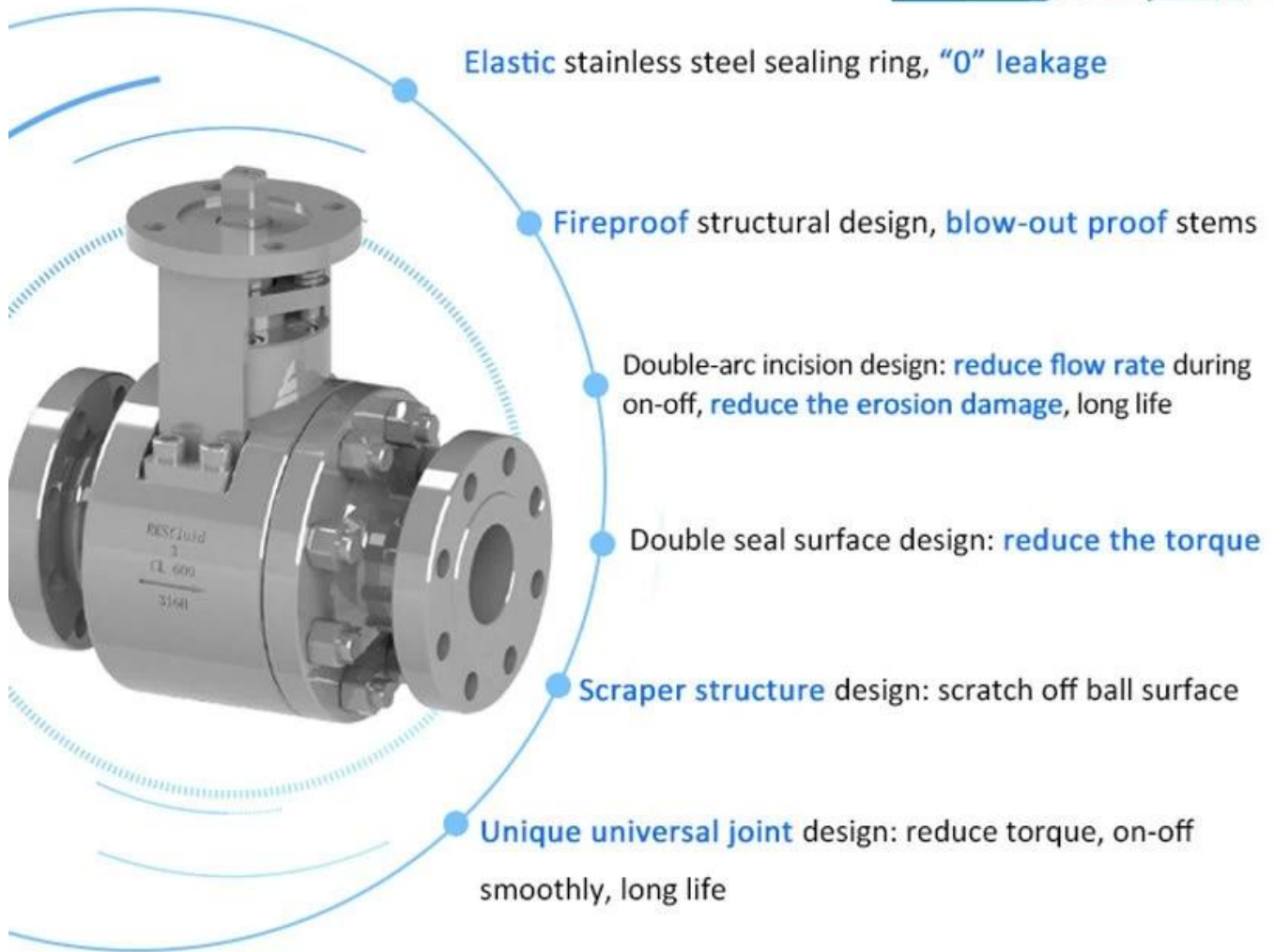



# APPLICATION SCENARIO



Industrial water application



Power plant



Petroleum



Steel



Wastewater treatment



Acid-base



Healing drugs



Refined coal



# Our Factory





# Company Advantages



I 100% high level ex-factory inspection

II 4 factories

III 2 professional testing centers

IV 2 years quality assurance, repair and replacement

V GB, TUV CE, ISO 9001, ADWO-2000, TS, PED, WRC, WRAS, KTW, API 6D, API609





