

1. ATHENA 24" 13" 14"

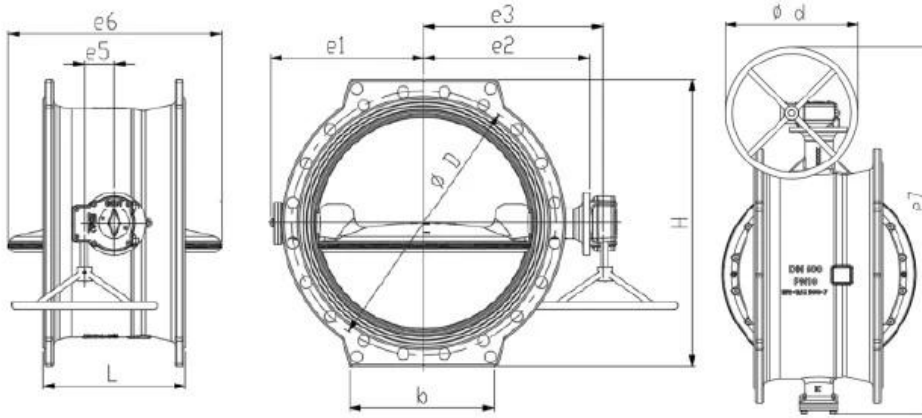

1. ATHENA 24" 13" 14"
2. 24" 13" 14"

1	DN200-DN1800
2	PN10 PN16 PN25 PN40
3	13" 14"
4	-10°C - 60°C
5	EN 593 EN1074-1/2
6	EN558 13 14
7	13" 14"

APPLICATION SCENARIO



Industrial water application



Power plant



Sea water desalination



Water treatment



Water supply and drainage



HAVC



Food and drug



Water transport



COMPANY FACTORY



01

21 years of professional experience

03

Independent research and development team
28 top senior professional researchers

05

100% high level ex-factory inspection

07

2 years quality assurance, repair and replacement

4 factories

02

2 professional testing centers

04

High quality imported materials

06

COMPANY QUALIFICATION



COMPANY EXHIBITION



Partners



