

## DESIGN FEATURES



### ● TECHNICAL REQUIREMENT

- 1.Design standard:BS 5163.
- 2.Face to face:BS 5163.
- 3.Flanges standard:BS EN1092-2:1997 PN16.
- 4.Test standard:BS EN12266-1 Rate B.

### ● FEATURES

- Double flange metal seated gate valve
- Size Range:DN50-DN2000
- Standard-ISO/BS/DIN/AWWA/API
- Tests Standard-BS EN 12266-1
- Body Ring-Bronze/SS420/SS304/SS316
- Body-Ductile Iron /Cast Iron/Stainless Steel /WCB
- Fusion bonded epoxy coating-min 300 microns



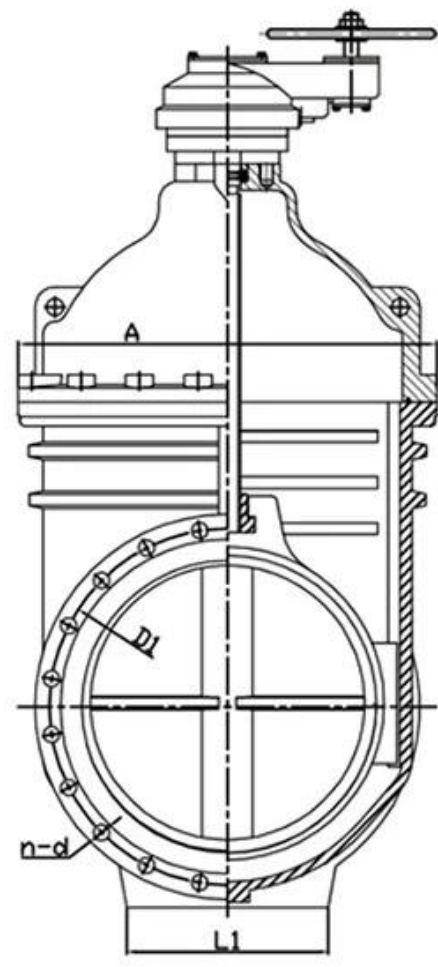
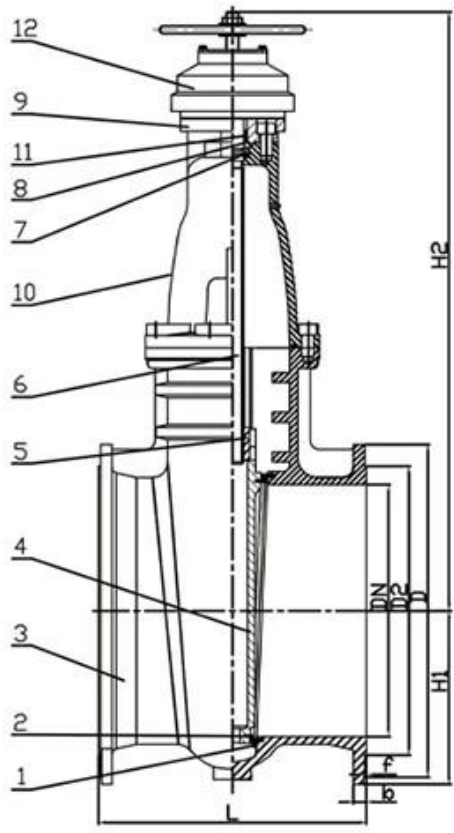

**RELATED PRODUCTS**



**SMALL DIAMETER GATE VALVE**  
DN50-DN300,PN10/16/25



**METAL SEATED GATE VALVE**  
DN350-DN600,PN10/16/25



**LARGE DIAMETER METAL SEATED GATE VALVE**  
DN700-DN2000,PN10/16/25

# APPLICATION SCENARIO



Industrial water application



Power plant



Sea water desalination



Water treatment



Water supply and drainage



HAVC



Food and drug



Water transport





COMPANY FACTORY



# COMPANY INFORMATION



i 工厂

ii CNC 工厂

iii 工厂

iv 工厂

v 工厂 GB 工厂 TUV CE ISO 9001 ADWO-2000 TS PED WRC WRAS KTW KTW API 6D API609

VI 工厂 / 工厂 / 工厂



01

21 years of professional experience

03

Independent research and development team  
28 top senior professional researchers

05

100% high level ex-factory inspection

07

2 years quality assurance, repair and replacement

4 factories

02

2 professional testing centers

04

High quality imported materials

06

# COMPANY QUALIFICATION





# COMPANY EXHIBITION



□□□□

□□□□□□□□□□□□□□□□  
 □□□□□□□□□□□□□□□□

□□□□□□□□□□□□□□  
 □□□□□□□hrdraulic□□□□□ RKSfluid□□□□□□□□□□□□□□□□

□□□□□□□□□□  
 □□RKSfluid□□□□□□□□□□□□

□□□□□□□□  
 □□□□□□□2□5□□□□□□□□□□□□□□□□□□□□

□□□  
 □□□□□□□1□□

□□□□□□□□□□  
 □□□□□100□□□□□□2□□□□□□□□□□□□□□□□□  
 □□□□□TUV□API□WRAS□CE□ISO□□□□  
 □□□□□DIN□ASME□BS EN□JIS□API□AWWA□

□□□□□□□□□□□□□□□□  
 □□RKSfluid□□20□□□□□□□□70□□□□□□□□□□□□□□□□□□□□