

RKSfluid®



RKSfluid®



RKSfluid®



RKSfluid®



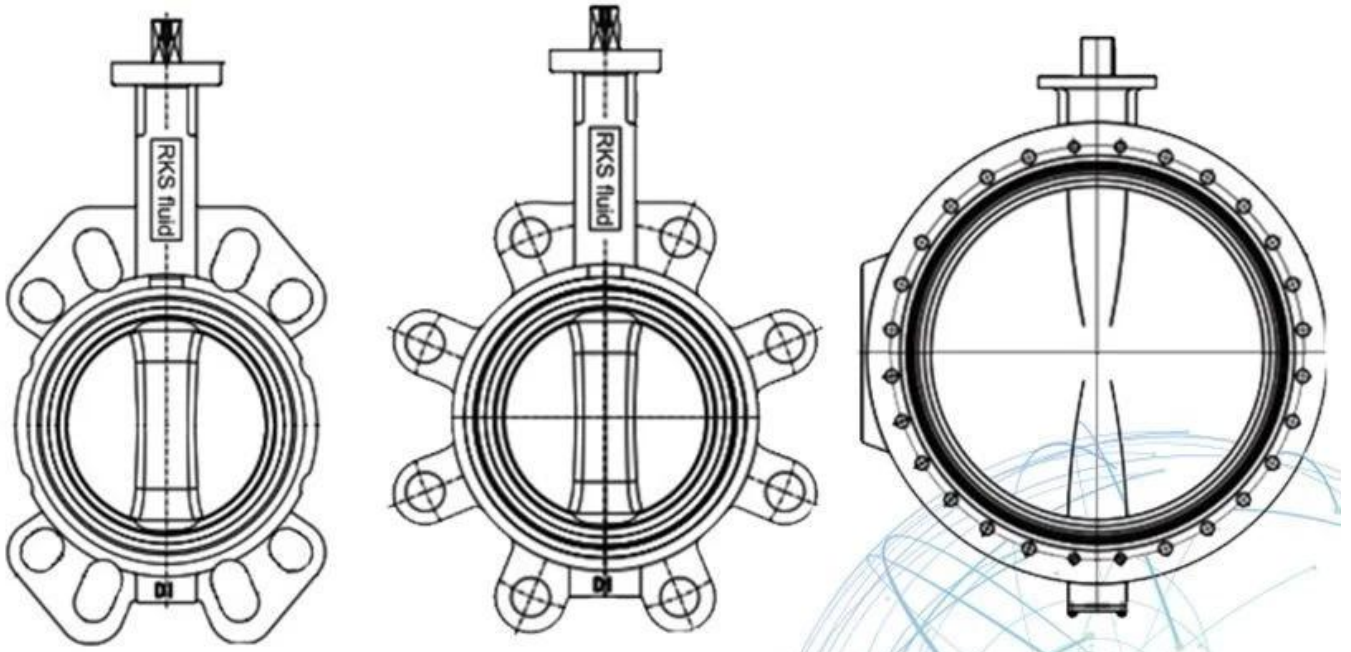

APPLICATION SCENARIO



Industrial water application



Power plant



Sea water desalination



Water treatment



Water supply and drainage



HAVC



Food and drug



Water transport



Our Factory



Exhibition Photos



Our Certificates



I Geschäftsbereich: Fluid Control-Produkte, Technologie- und Umweltschutzprodukte.

II Fortgeschrittene CNC-Bearbeitungszentren, professionelle Prozesszellen, Schweißgeräte mit großer Bandbreite, automatische Montagelinien und Beschichtungen.

III Chinas Standardreferenzeinheit, um an der Entwicklung relevanter Normen für die

Ventilindustrie mitzuwirken.

IV Wir haben in Houston, Texas, USA, ein Forschungs- und Entwicklungszentrum eingerichtet.

V Produktnorm: GB, Deutsche Norm, Amerikanische Norm, TÜV CE, ISO 9001, ADWO-2000, TS, DGRL, WRC WRAS, KTW, API 6D, API609.

VI Hauptproduktion: Absperrklappe, Kugelhahn, Absperrschieber, Rückschlagklappe, Absperrklappen, Rohrverschraubungen, manueller / pneumatischer / elektrischer Antrieb, Ventileile.