

DESIGN FEATURES

DURABLE

- No-pin connection, 1 pc blow-out proof stem
- DI/CI Nodularity over 95%

ANTI-CORROSION

- Material: Epoxy powder:  , Earth Best!
- Coating Thickness: 200-250µm
- Spraying temp: over 200°C. Doesn't fade, even wipe with diethyl ether

QUALITY STANDARD

- 100% quality test, follow DIN, ASTM, JIS, GB/T, ISO, BS EN, API
- ONLY ONE Manufacturer get CE certification up to DN1800
- 2 years warranty. 15000 times On-off test, 30000 times Destructive experiment

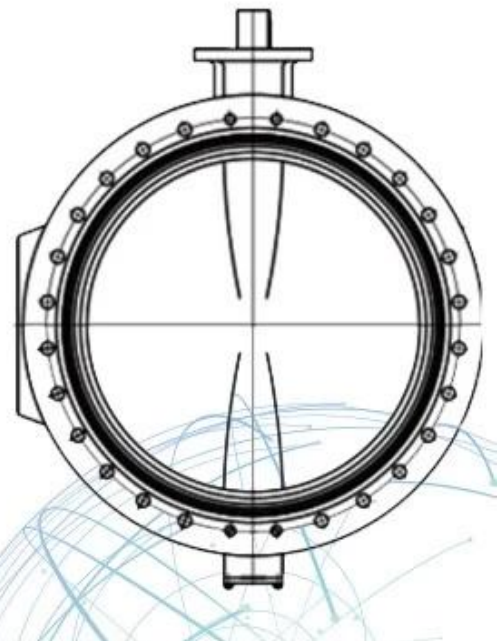
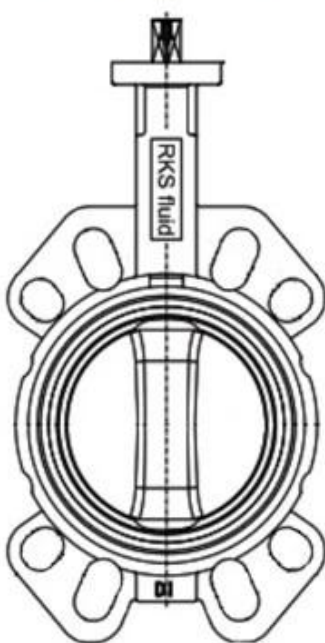

Größe	DN32 - DN2400 (NPS1 1/4-NPS96)
Druckstufen	PN6 - PN10 - PN16 (Klasse 150)
Temperaturbereich	-40°C-120°C

Material	Sphäroguss, Edelstahl usw.
Sitzmaterial	NBR, EPDM, Naturkautschuk, Silikon, Viton
Verbindung	Wafer, Lug, U-Profil, Doppelflansch



WAFER

LUG

NPS14-NPS40 Wafer/Lug with alignment holes

Size	L	H1	H2	h	A	ΦB	C	ΦG	a	b	ΦD	n-Φd	ISO5211
NPS14	3.07	10.63	11.81	1.42	1.06	Φ13.31	12.95	-	-	-	Φ4.92	4-Φ0.55	F12
NPS16	4.02	11.81	13.58	1.69	1.26	Φ15.35	14.80	-	-	-	Φ5.50	4-Φ0.71	F14
NPS18	4.49	12.99	14.76	1.93	4.42	Φ17.20	16.61	-	-	-	Φ5.50	4-Φ0.71	F14
NPS20	5.00	15.16	16.73	2.56	-	Φ19.09	18.43	Φ2.36	0.71	2.52	Φ6.50	4-Φ0.87	F16
NPS24	6.06	17.24	19.49	2.76	-	Φ23.03	22.24	Φ2.36	0.71	2.52	Φ6.50	4-Φ0.87	F16
NPS28	6.50	20.39	22.44	3.15	-	Φ26.77	25.98	Φ2.76	0.79	2.93	Φ10.00	8-Φ0.71	F25
NPS30	6.50	21.46	24.02	3.15	-	Φ28.74	27.95	Φ2.76	0.79	2.93	Φ10.00	8-Φ0.71	F25
NPS32	7.48	22.32	25.20	3.15	-	Φ30.43	29.49	Φ2.76	0.79	2.93	Φ10.00	8-Φ0.71	F25
NPS36	7.99	25.59	27.56	3.94	-	Φ34.49	33.54	Φ3.15	0.87	3.35	Φ10.00	8-Φ0.71	F25
NPS40	8.50	28.15	29.53	3.94	-	Φ38.43	37.48	Φ3.15	0.87	3.35	Φ11.73	8-Φ0.87	F30

APPLICATION SCENARIO



Industrial water application



Power plant



Sea water desalination



Water treatment



Water supply and drainage



HAVC



Food and drug



Water transport



COMPANY INFORMATION



I Geschäftsbereich: Produkte zur Flüssigkeitskontrolle, Technologie und Umweltschutzprodukte.

II Fortschrittliche CNC-Bearbeitungszentren, professionelle Prozesszellen, umfangreiche Schweißausrüstung, automatische Montagelinien und Beschichtung.

III Chinas Standard-Referenzeinheit, um an der Entwicklung relevanter Standards für die Ventilindustrie teilzunehmen.

IV Wir haben ein Forschungs- und Entwicklungszentrum in Houston, Texas, in den Vereinigten Staaten eingerichtet.

V Produktstandard: GB, deutscher Standard, amerikanischer Standard, TÜV CE, ISO 9001, ADWO-2000, TS, PED, WRC WRAS, KTW, API 6D, API609.

VI Hauptproduktion: [Absperrklappe](#), Kugelhahn, Absperrschieber, Rückschlagventil, Kugelventile, Rohrverschraubungen, manuelle/pneumatische/elektrische Stellantriebe, Ventileile.



01

21 years of professional experience

03

Independent research and development team
28 top senior professional researchers

05

100% high level ex-factory inspection

07

2 years quality assurance, repair and replacement

4 factories

02

2 professional testing centers

04

High quality imported materials

06

COMPANY QUALIFICATION



COMPANY EXHIBITION



Partners



Delivery



Payment



FAQ:

F: Welche Informationen benötigen wir, wenn ich ein Angebot benötige?

A: Ventilmaterialien, Temperatur, Druck, Medium, Anwendungssystem.

F: Können Sie Aktuatoren bereitstellen, was Sie haben?

A: Pneumatische, elektrische, hydraulische, Magnetventile. RKSfluid Aktuatoren übernehmen USA-Technologie. Was Sie brauchen, sagen Sie uns einfach.

F: Wie hoch ist Ihre Produktionskapazität?

A: RKSfluid verfügt über vier Werke, die die von Ihnen benötigten Produkte liefern können.

F: Produktionsvorlaufzeit

A: Normale Produkte sind innerhalb von 2 bis 5 Werktagen auf Lager. Maßgeschneidert auf Ihren Bedarf.

F: MOQ

A: 1 Stück für alle Produkte.

F: Wie sieht es mit der Qualitätssicherung aus?

A: 100 % Qualitätsprüfung vor der Auslieferung, 2 Jahre Garantie. Sorgen Sie für die Betriebssicherheit Ihres Systems.

Wir haben TÜV-, API-, WRAS-, CE- und ISO-Zertifizierung.

Standardkonform mit DIN, ASME, BS EN, JIS, API, AWWA.

F: Wie können Sie unseren Kunden einen qualitativ hochwertigen Service bieten?

A: RKSfluid Wir besitzen 20 Jahre Erfahrung und mehr als 70 Forschungs- und Entwicklungsingenieure bieten Ihnen technischen Support, Modellauswahl und Installationsanleitung.