

RKSfluid®



RKSfluid®



RKSfluid®



RKSfluid®



RKSfluid

RKSfluid®



RKSfluid®



DESIGN FEATURES

DURABLE

- No-pin connection, 1 pc blow-out proof stem
- DI/CI Nodularity over 95%

ANTI-CORROSION

- Material: Epoxy powder:  , Earth Best!
- Coating Thickness: 200-250µm
- Spraying temp: over 200°C. Doesn't fade, even wipe with diethyl ether

QUALITY STANDARD

- 100% quality test, follow DIN, ASTM, JIS, GB/T, ISO, BS EN, API
- ONLY ONE Manufacturer get CE certification up to DN1800
- 2 years warranty. 15000 times On-off test, 30000 times Destructive experiment



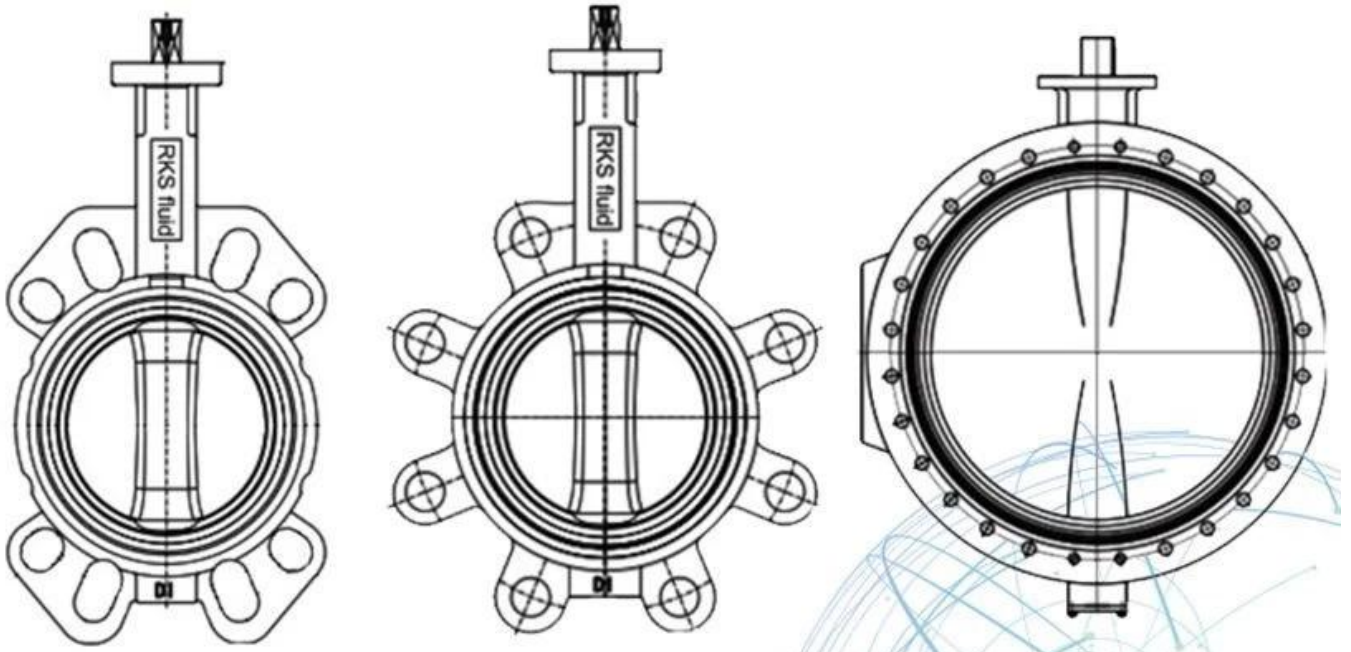

APPLICATION SCENARIO



Industrial water application



Power plant



Sea water desalination



Water treatment



Water supply and drainage



HAVC



Food and drug



Water transport



Our Factory



FAQ

F: Wenn ich ein Angebot benötige, welche Informationen benötigen wir?

A: Materialien der Ventile, Temperatur, Druck, Medium, Anwendungssystem.

F: Können Sie Stellantriebe bereitstellen, was Sie haben?

A: Pneumatische, elektrische, hydraulische, Magnetventile. RKSfluid-Antriebe übernehmen die USA-Technologie. Was Sie brauchen, sagen Sie uns einfach.

Q: Was ist Ihre Produktionskapazität?

A: RKSfluid verfügt über vier Werke, die die Produkte liefern, die Sie benötigen.

Q: vorlaufzeit

A: Normale Produkte haben Lager in 2 ~ 5 Arbeitstagen. Maßgeschneiderte basis auf ihre notwendigkeit.

Q: MOQ

A: 1 stück für alle produkte.

Q: wie über die Qualitätssicherung?

A: 100% qualitätsprüfung vor anlieferung, 2 jahre garantie. Stellen Sie die Sicherheit Ihres Systems sicher.

Wir haben TÜV, API, WRAS, CE, ISO zertifizierung.

Standard entsprechen DIN, ASME, BS EN, JIS, API, AWWA.

F: Wie können Sie unseren Kunden qualitativ hochwertigen Service bieten?

A: RKSfluid besitzt 20 Jahre Erfahrung und mehr als 70 Forschungs- und Entwicklungsingenieure bieten technischen Support, Modellauswahl und Installationsanleitung für Sie.

Exhibition Photos



Our Certificates

