

DESIGN FEATURES

Features

1. Streamlined: minimum noise
2. Anti-static design
3. Double Block & Bleed
4. Automatic Self-Venting Seats
5. Emergency Protection

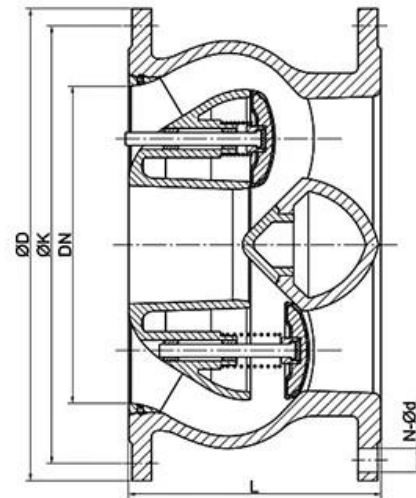

APPLICATION SCENARIO



Industrial water application



Power plant



Sea water desalination



Water treatment



Water supply and drainage



HAVC



Food and drug



Water transport



COMPANY INFORMATION



I Geschäftsbereich: Produkte für Flüssigkeitskontrolle, Technologie und Umweltschutzprodukte.

II Fortgeschrittene CNC-Bearbeitungszentren, professionelle Prozesszellen, Weitbereichsschweißgeräte, automatische Montagelinien und Beschichtung.

III Chinas Standardreferenzeinheit zur Teilnahme an der Entwicklung relevanter Standards der Valvilbranche.

IV Wir haben in den USA ein Forschungs- und Entwicklungszentrum in Houston, Texas, eingerichtet.

V Produktstandard: GB, Deutscher Standard, American Standard, Tuv CE, ISO 9001, ADWO-2000, TS, PED, WRC WRAS, KTW, API 6d, API609.

VI -Hauptproduktion: Schmetterlingsventil, Kugelventil, Ventil, Scheckventil, Globusventile, Rohrbeschläge, manuell / pneumatischer / elektrischer Aktuator, Ventiltteile.

01

21 years of professional experience

03

Independent research and development team
28 top senior professional researchers

05

100% high level ex-factory inspection

07

2 years quality assurance, repair and replacement

4 factories

02

2 professional testing centers

04

High quality imported materials

06

COMPANY QUALIFICATION



COMPANY EXHIBITION



FAQ

F: Wenn ich ein Angebot benötige, welche Informationen brauchen wir?

A: Materialien, Temperatur, Druck, Medium, Application System.

F: Können Sie Aktuatoren zur Verfügung stellen, was Sie haben?

A: Pneumatische, elektrische, hydraulische, Magnetventile. RKSfluid -Aktuatoren übernehmen die USA -Technologie. Was Sie brauchen, sagen Sie es uns einfach.

F: Was ist Ihre produktive Kapazität?

A: RKSfluid verfügt über vier Pflanzen, die die von Ihnen benötigten Produkte bereitstellen können.

F: Vorlaufzeit der Produktion

A: Normale Produkte haben in 2 bis 5 Arbeitstagen Lagerbestände. Anpassende Basis auf Ihr Bedürfnis.

F: Moq

A: 1PC für alle Produkte.

F: Wie wäre es mit der Qualitätssicherung?

A: 100% Qualitätstest vor der Lieferung, 2 Jahre Garantie. Stellen Sie sicher, dass Ihr System die Sicherheit bearbeitet.

Wir haben TUV, API, WRAS, CE, ISO -Zertifizierung.

Standard entspricht DIN, ASME, BS EN, JIS, API, Awwa.

F: Wie können Sie unseren Kunden einen hochwertigen Service bieten?

A: RKSfluid eigene 20 -jährige Erfahrungen und mehr als 70 F & E -Ingenieure bieten technische Unterstützung, Modellauswahl und Installationsanleitung für Sie.