



RKSfluid®

A key Valve in Flow Control



Butterfly Valve



Ball Valve



Gate Valve



Globe Valve



Check Valve



Pipe Fittings

DESIGN FEATURES



SPECIFICATION		
Nominal pressure (MPa)	1.6	
Testing pressure(MPa)	Seal	2.4
	Shell	1.76
Working pressure (MPa)	1.6	
Suitable temperature (°c)	<80°c	
Suitable medium	Water	

TECHNICAL REQUIREMENT	
1.Face to face standard: EN 558 Series 14.	
2.Flanges standard: BS EN1092-2:1997 PN16.	
3.Tests standard: BS EN12266-1:2003 Part 1 Rate A.	

DESCRIPTION :

- ◆ Double Flange Eccentric Resilient Seated Butterfly Valve
- ◆ Size Range DN100-DN3000
- ◆ Standard - ISO / BS / DIN / AWWA /API
- ◆ Tests Standard - BS EN 12266-1
- ◆ Body - Ductile Iron / Cast Iron /Stainless Steel / WCB
- ◆ Disc - Ductile Iron / Cast Iron / Stainless Steel / WCB
- ◆ Body Ring -SS420 / SS304 / SS316
- ◆ Retaining Ring - SS420 / SS304 / SS316
- ◆ Disc Ring -EPDM
- ◆ Shaft - SS420 / SS431 / SS316
- ◆ Fusion Bonded Epoxy Coating - Min 300 Microns

The designs, material and specifications shown are subject to change without notice due to our continuing programme of product development.

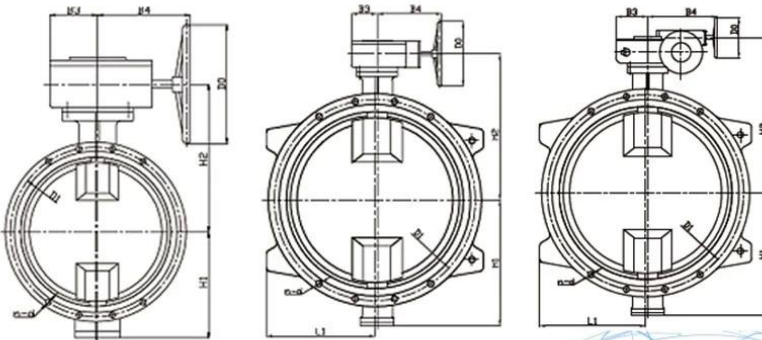

DN100-DN600

DN700-DN800

DN900-DN3000

APPLICATION SCENARIO



Our Factory



RKS fluid wurde 1997 gegründet. Wir sind eine Produktionswerkstatt für Gießerei und Zerspanung, ein Forschungs- und Entwicklungszentrum sowie ein Qualitätskontrollzentrum. Die Produktionsanlagen umfassen CNC-Bearbeitungszentren, professionelle Bearbeitungszellen, Breitbandschweißgeräte, automatische Montage- und Beschichtungslinien. Wir haben ein Team für Design, Forschung und Entwicklung zusammengestellt.

Unser neues Testzentrum als Testzentrum für öffentliche Serviceplattformen in der Provinz Liaoning wird zum Standard-GB der chinesischen Ventilreferenzeinheit, um an der Entwicklung der relevanten Normen für die Ventilindustrie mitzuwirken. Um den Ausbau des Auslandsgeschäfts und die Integration von Ressourcen zu beschleunigen und den Erfolg des RKS-Flüssigkeitsvertriebs in den USA, Deutschland und Russland zu unterstützen. Wir haben US-Agent. Unsere Produktdesign-Standards umfassen: GB, ISO, deutsche und amerikanische Norm, vom TÜV für CE und ADWO-2000, ISO9001, TS, API genehmigt. Unsere Produkte: Manuelle, pneumatisch und elektrisch betätigte Kugelhähne, Absperrklappen und Absperrschieber. Rückschlagventile, automatische Regelventile. Gussteile und Armaturen: Ventilkörper, Motorhauben, Scheiben, Vorbauten, Getriebe, Universalkupplungen, Flanschadapter, Gewindebohrsättel. Nach Jahren der Entwicklung verbessern und suchen wir nach Innovationen, wobei wir uns an die bewährte Technologie, herausragende Eigenschaften und den legendären Wert halten "als unsere Produktwertphilosophie. Kundenzufriedenheit ist unser Arbeitsziel!

Our Certificates



Exhibition Photos

