

## DESIGN FEATURES



### Features



- Use AkzoNobel material.
- Super Anti-corrosion
- Epoxy powder coating 200-250um,
- Baking varnish over 200°C,

NO.		
1	Body	GGG50
2	Dise	GGG40+EPDM
3	Wedge nut	C48600
4	Stem	SS431
5	Bonnet	GT450-10
6	Gasket	EPDM
7	Y-ring	EPDM85-90
8	Fix ring	CuZn21Si3/C69300
9	Thrust bearing	C69300
10	Seal ring	EPDM70
11	O ring	NBR
12	Retainer ring	POM
13	Bushing ring	POM
14	Gland	SS431
15	Dustproof ring	EPDM85
16	Dise core	GGG40
17	Bolt	SS316

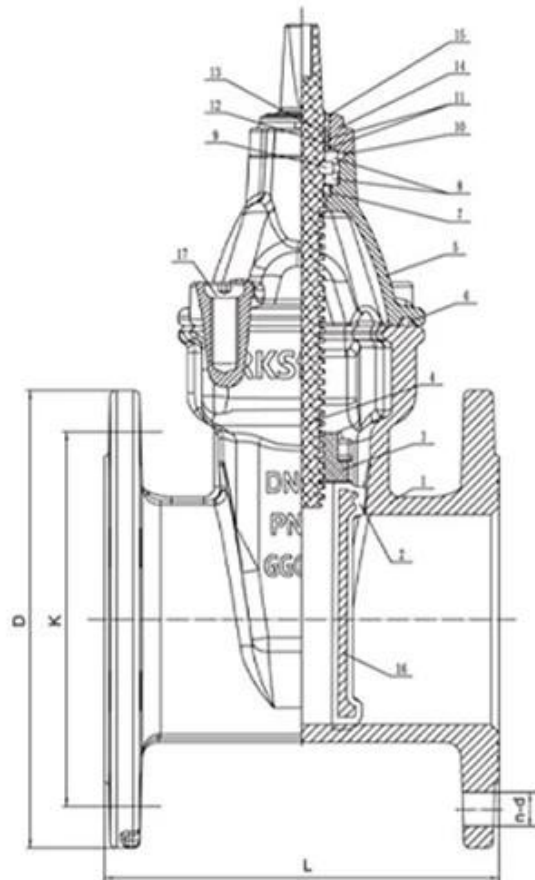



Free wedge nut, **reduces the stem bending forces** and at the same time enables it to be easily replaced.



The more compact new cap, **reduces the water retention areas** in order to reduce the risk of bacterial growth.



One piece stainless steel stem in for **better resistance to axial load** and to with stand higher operating torques.



**Three locking tab** for bayonet system prevents self-dismantling.



Dust guard integrating three O-ring shape, **prohibiting the introduction of foreign bodies** at the stem.



**Male guiding system with composite sliding skate** reduces the wear of the wedge against the body, allowing a smooth functionality and a longer life time of the valve.



**Triple seal at the operating stem** to ensure tightness with the test of time (2500 cycles).



**New male composite sliding skate technology** ensuring a low operating torque even under high differential pressure and preventing damage or corrosion generated by the friction.

## RELATED PRODUCTS

---



# APPLICATION SCENARIO



Industrial water application



Power plant



Sea water desalination



Water treatment



Water supply and drainage



HAVC



Food and drug



Water transport





## COMPANY INFORMATION



I Área comercial: productos de control de fluidos, tecnología y productos de protección ambiental.

II Centros de mecanizado CNC avanzados, celdas de proceso profesional, equipos de soldadura de amplio rango, líneas de ensamblaje automáticas y recubrimiento.

III La unidad de referencia estándar de China, para participar en el desarrollo de los estándares relevantes de la industria de las válvulas.

IV Hemos establecido un centro de investigación y desarrollo en Houston, Texas, en los Estados Unidos.

V Estándar del producto: GB, Standard alemán, Estándar Americano, TUV CE, ISO 9001, ADWO-2000, TS, PED, WRC WRAS, KTW, API 6D, API609.

VI Producción principal: válvula de mariposa, válvula de bola, válvula de compuerta, válvula de retención, válvulas de globo, accesorios de tubería, actuador manual / neumático / eléctrico, piezas de válvula.

# COMPANY FACTORY





# COMPANY QUALIFICATION



## COMPANY EXHIBITION



### Preguntas más frecuentes

**P: Si necesito una cita, ¿qué información necesitamos?**

R: Materiales de válvulas, temperatura, presión, medio, sistema de aplicaciones.

**P: ¿Puede proporcionar actuadores, lo que tiene?**

A: válvulas neumáticas, eléctricas, hidráulicas, solenoides. Los actuadores RKSfluid adoptan la tecnología de EE. UU. Lo que necesitas, solo dime.

**P: ¿Cuál es su capacidad productiva?**

R: RKSfluid tiene cuatro plantas que pueden proporcionar los productos que necesita.

**P: Tiempo de entrega de producción**

R: Los productos normales tienen stock en 2 ~ 5 días hábiles. Base personalizada en su necesidad.

**P: MOQ**

A: 1 PC para todos los productos.

**P: ¿Qué tal la garantía de calidad?**

R: Prueba de calidad del 100% antes de la entrega, 2 años de garantía. Asegúrese de que su sistema funcione con seguridad.

Tenemos TUV, API, WRAS, CE, Certificación ISO.

Estándar conformes a DIN, ASME, BS EN, JIS, API, AWWA.

P: ¿Cómo podría proporcionar un servicio de calidad a nuestros clientes?



R: RKSfluid posee experiencias de 20 años y más de 70 ingenieros de I + D brindan soporte técnico, selección de modelos y orientación de instalación para usted.