

### **Características:**

Fully bore globe pattern design, lowest head loss while fully open

Keep stable working condition even the flow rate close to zero

High sensitive and strength fabric reinforced diaphragm

- 1000000 cycles test between fully close and open with working pressure

- 5 times of working pressure destructive test

Most components are machined by CNC

Fusion bonded epoxy coating process is based on GSK & WIS standard

High standard production test

- Seal test: Low pressure 0.5 bar

High pressure 1.1xPN+1 bar

- Shell test: 1.5xPN+1 bar

- Pressure modulated vibration: +/-0.2 bar

Data collected automatically 1000 times/sec, display with static or dynamic chart

Easy installation, operation and free maintenance

Different materials with WRAS/KTW/NSF/FDA/ACS certification to meet different market

|                          |   |
|--------------------------|---|
| Size                     | DN40-DN1200   |
| Working Medium           | Water   |
| Temperature              | 0°C~70°C  |
| Material                 | Ductile Iron/Stainless Steel/Cast Steel/Bronze/Aluminum Alloy |
| Design Standards         | CJ/T 219 & JB/T 10674 & EN 1074-5                             |
| Pressure Level           | PN10, PN16, PN25  |
| Stress Test Standard     | GB/T 13927 & ISO 5208 & EN12266-1                             |
| Flange drilling standard | GB17241.6; EN1092-2; ISO7005-2; ANSI / JIS / AS2129           |
| Structure Length         | GB 12221 & EN558-1  |

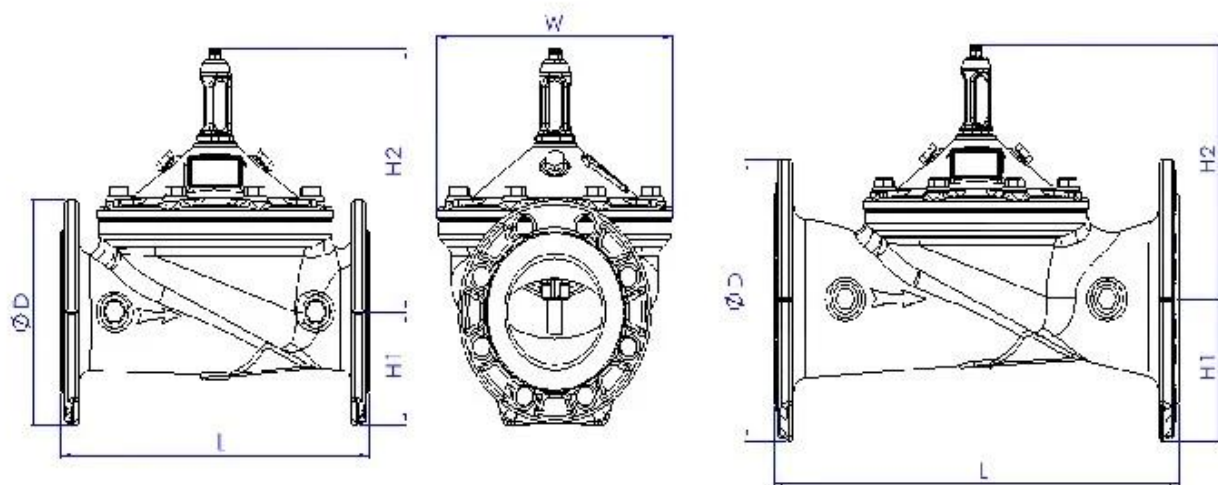

| DN  | L   | H   | H1  | DN   | L    | H    | H1  |
|-----|-----|-----|-----|------|------|------|-----|
| 40  | 230 | 139 | 85  | 250  | 730  | 476  | 205 |
| 50  | 230 | 139 | 85  | 300  | 850  | 526  | 232 |
| 65  | 290 | 159 | 95  | 350  | 980  | 585  | 262 |
| 80  | 310 | 179 | 102 | 400  | 1100 | 624  | 292 |
| 100 | 350 | 214 | 112 | 500  | 1250 | 720  | 360 |
| 125 | 400 | 278 | 127 | 600  | 1450 | 835  | 425 |
| 150 | 480 | 333 | 145 | 800  | 1850 | 1110 | 515 |
| 200 | 600 | 407 | 172 | 1000 | 2250 | 1350 | 630 |

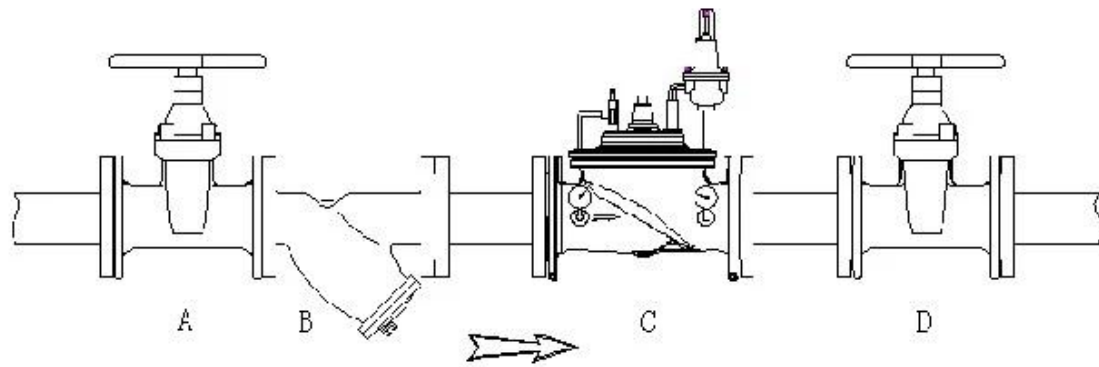

### Área de aplicación

urban water supply and industrial [agricultural water transmission lines, etc.]

### Principio de funcionamiento

pressure reducing valve is an accurate and pilot controlled valve [It can be reduce a high inlet water pressure to a steady downstream pressure regardless of the inlet water pressure chanding.]



I Business area: fluid control products, technology and environmental protection products.

II Advanced CNC machining centers, professional process cells, wide-range welding equipment, automatic assembly lines and coating.

III China's standard reference unit, to participate in the development of relevant valve industry standards.

IV We have set up a research and development center in Houston, Texas, in the United States.

V Product Standard: GB, German Standard, American Standard, TUV CE, ISO 9001, ADWO-2000, TS, PED, WRC WRAS, KTW, API 6D, API609.

VI Main production: válvula de mariposa, ball valve, gate valve, check valve, globe valves, pipe fittings, manual / pneumatic / electric actuator, valve parts



## Exhibition Photos



## Our Certificates



Preguntas más frecuentes

**Q: If I need quotation, what informations do we need?**

A: Valves' materials, Temperature, Pressure, Medium, Appllication System.

**Q: Can you provide actuators, what you have?**

A: Pneumatic, Electric, Hrdraulic, Solenoid Valves. RKSfluid actuators adopt USA technology. Which you need, just tell us.

**Q: What's your productive capacity?**

A: RKSfluid has four plants that can provide the products you need.

**Q: Production lead time**

A: Normal products have stock in 2~5 working days. Customized base on your need.

**Q: MOQ**

A: 1pc for all products.

**Q: How about the quality assurance?**

A: 100% quality test before delivery, 2 years warranty. Ensure your system working safety. We got TUV, API, WRAS, CE, ISO certification. Standard conform to DIN, ASME, BS EN, JIS, API, AWWA.

**Q: How could you provide quality service to our customers?**

A: RKSfluid own 20 years experiences and more than 70 R&D engineers provide technical support, model selection and installation guidance for you.