



RKSfluid®

A key Valve in Flow Control



Butterfly Valve



Ball Valve



Gate Valve



Globe Valve



Check Valve



Pipe Fittings

DN32/40~DN300

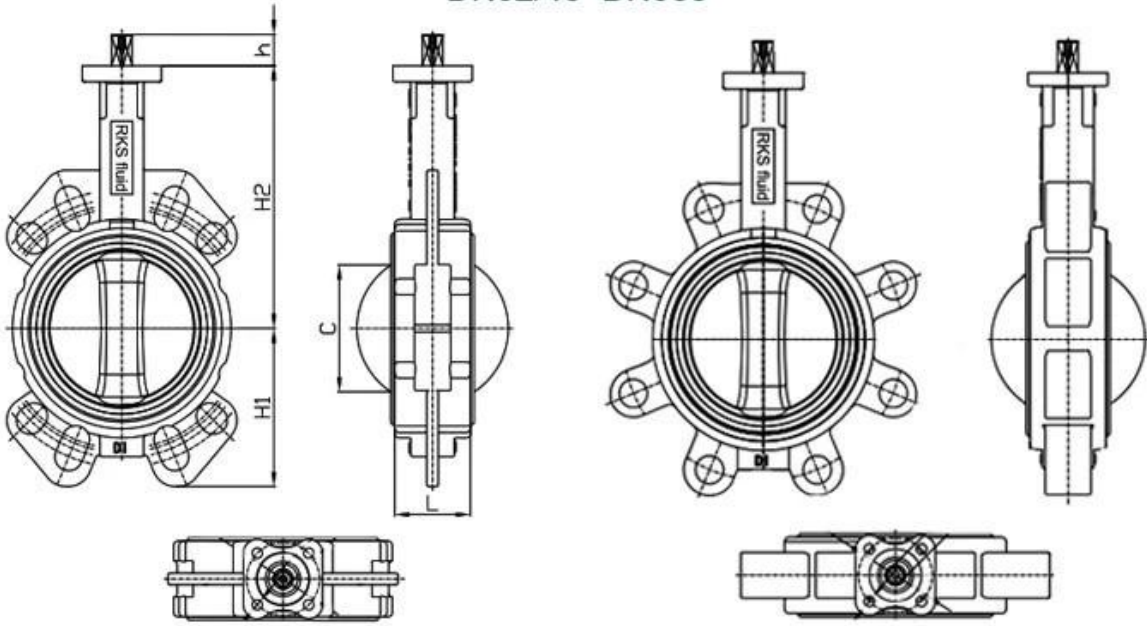

DN350~DN1000

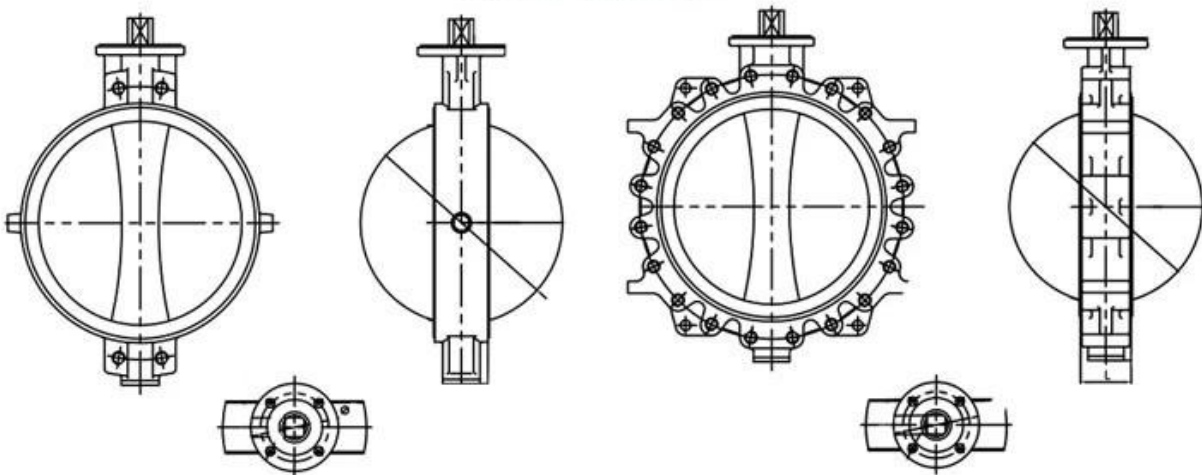

DN500~DN2400

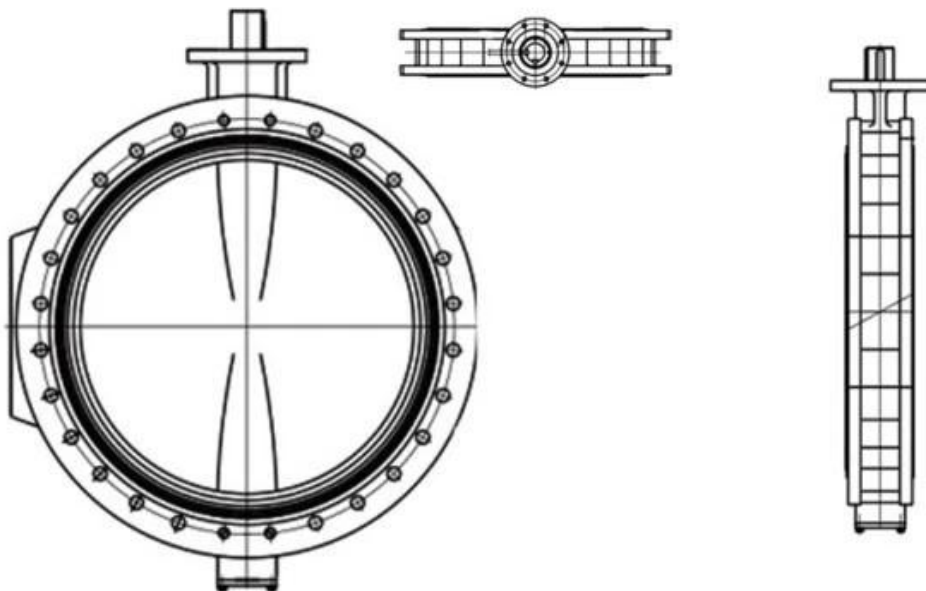

DESIGN FEATURES

DURABLE

- No-pin connection, 1 pc blow-out proof stem
- DI/CI Nodularity over 95%

ANTI-CORROSION

- Material: Epoxy powder:  , Earth Best!
- Coating Thickness: 200-250µm
- Spraying temp: over 200°C. Doesn't fade, even wipe with diethyl ether

QUALITY STANDARD

- 100% quality test, follow DIN, ASTM, JIS, GB/T, ISO, BS EN, API
- ONLY ONE Manufacturer get CE certification up to DN1800
- 2 years warranty. 15000 times On-off test, 30000 times Destructive experiment



APPLICATION SCENARIO



Industrial water application



Power plant



Sea water desalination



Water treatment



Water supply and drainage



HAVC



Food and drug



Water transport





PTFE lined butterfly valve



Resilient seat butterfly valve



Double offset butterfly valve



Triple offset butterfly valve



Ball valve



Pipe fittings

Domaine d'activité: produits de contrôle des fluides, produits technologiques et de protection de l'environnement.

Il Centres d'usinage CNC avancés, cellules de processus professionnelles, équipements de soudage à large plage, lignes de montage et revêtements automatiques.

Unit Unité de référence standard de la Chine, pour participer à l'élaboration des normes pertinentes du secteur des vannes.

IV Nous avons créé un centre de recherche et développement à Houston, au Texas, aux États-Unis.

Standard Norme de produit: GB, norme allemande, norme américaine, CE TUV, ISO 9001, ADWO-2000, TS, PED, WRC WRAS, KTW, API 6D, API609.

VI Production principale: vanne papillon, vanne à boisseau sphérique, vanne vanne, clapet anti-retour, vannes à soupape, raccords de tuyauterie, actionneur manuel / pneumatique / électrique, pièces de vanne.

Our Factory



Company Advantages

01

21 years of professional experience

03

Independent research and development team
28 top senior professional researchers

05

100% high level ex-factory inspection

07

2 years quality assurance, repair and replacement

4 factories

02

2 professional testing centers

04

High quality imported materials

06

Exhibition Photos



Our Certificates



FAQ

Q: Si j'ai besoin d'un devis, de quelles informations avons-nous besoin?

A: Matériaux des vannes, température, pression, milieu, système d'application.

Q: Pouvez-vous fournir des actionneurs, ce que vous avez?

A: Valves pneumatiques, électriques, hydrauliques, à solénoïde. Les actionneurs RKSfluid adoptent la technologie américaine. Dites-nous ce dont vous avez besoin.

Q: Quelle est votre capacité de production?

A: RKSfluid a quatre usines qui peuvent fournir les produits dont vous avez besoin.

Q: délai de production

A: Les produits normaux ont un stock en 2 ~ 5 jours ouvrables. Base personnalisée selon vos besoins.

Q: MOQ

Un: 1 pc pour tous les produits.

Q: qu'en est-il de l'assurance qualité?

A: test de qualité à 100% avant la livraison, garantie de 2 ans. Assurez la sécurité de votre système.

Nous avons obtenu la certification TUV, API, WRAS, CE et ISO.

Conforme aux normes DIN, ASME, BS EN, JIS, API, AWWA.

Q: Comment pourriez-vous fournir un service de qualité à nos clients?

R: RKSfluid possède 20 ans d'expérience et plus de 70 ingénieurs en recherche et développement vous apportent une assistance technique, une sélection de modèles et des conseils pour l'installation.