



- Fireproof structural design, API607 / API6FA Standard
- Flexible sealing ring structure, reliable seating
- Safety locking device, error prevention
- Double block & bleed
- Anti-static design

TYPHON series Metal Seal Ball Valve

Design Features



- The whole configuration -

TYPHON series valve is a floating uni-directional seated ball valve. It includes the main body, secondary body, the main seat, secondary seat, belleville spring, ball, universal joint, stem, packing gland, packing. The body, seat and ball are forged. The maximum temperature endurance is 800 °C. It is used for three-phase flow (gas, solid, liquid), high erosion, high hard granular media, easy to coke materials and high frequency switching conditions.

- Full metal Hard seal -

Between the ball and the seat is metal spherical seal. Between the main seat and the body is the metal flat seal. There is no non-metallic gasket between the seals. The seal pair has tested to "zero leakage".

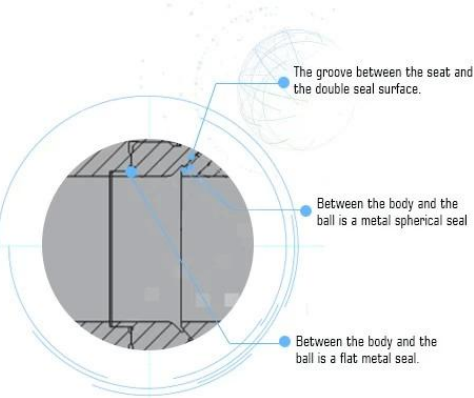

The groove between the seat and the double seal surface.

Between the body and the ball is a metal spherical seal

Between the body and the ball is a flat metal seal.

- Double-arc incision design -

The ball inlet and outlet are designed for double-arc incision, and the two incisions are rotated 180 degrees symmetrically. This design can instantaneously expand the flow area when open and close, reducing the media flow rate, thereby reducing the erosion damage of the ball and the valve seat sealing surface, extending the service life of the valve.

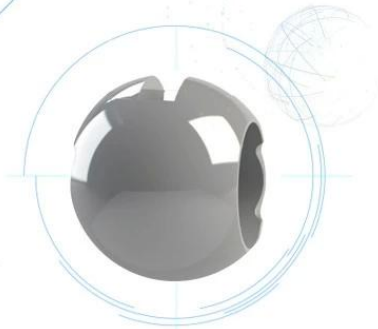
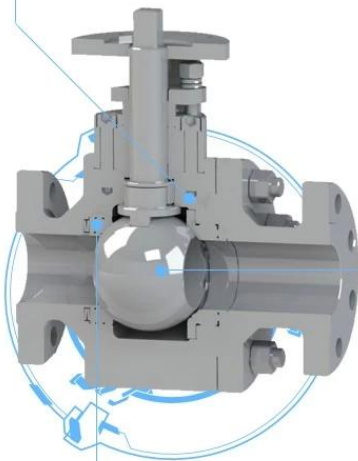

- Spring box design -

The side seat is installed in the seat pocket of the main body. The belleville spring is installed in the spring box formed by the body and the seat. The inner and outer sides of the secondary seat are provided with labyrinth grooves, which prevent the media particles from entering the spring chamber and affecting the spring action.

The secondary seat is driven by a spring to move along the passage axis while providing the preload between the main seat, the secondary seat and the ball.

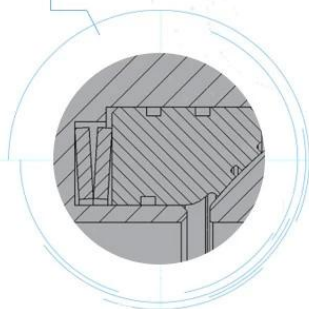

Engineering Projects



Partners



PTFE lined butterfly valve



Resilient seat butterfly valve



Double offset butterfly valve



Triple offset butterfly valve



Ball valve



Pipe fittings

Our Factory



Company Advantages

01

21 years of professional experience

03

Independent research and development team
28 top senior professional researchers

05

100% high level ex-factory inspection

07

2 years quality assurance, repair and replacement

4 factories

02

2 professional testing centers

04

High quality imported materials

06



I Domaine d'activité: produits de contrôle des fluides, technologie et produits de protection de l'environnement.

II Centres d'usinage CNC avancés, cellules de traitement professionnelles, équipement de soudage, chaînes de montage automatiques et revêtement.

III Unité de référence standard chinoise, pour participer à l'élaboration des normes pertinentes de l'industrie des vannes.

IV Nous avons mis en place un centre de recherche et développement à Houston, Texas, aux États-Unis.

V Norme de produit: GB, norme allemande, norme américaine, TUV CE, ISO 9001, ADWO-2000, TS, PED, WRC WRAS, KTW, API 6D, API609.

VI Production principale: vanne papillon, vanne à boisseau sphérique, vanne à clapet anti-retour, robinets à soupape, accessoires de tube, actionneur manuel / pneumatique / électrique, pièces de vanne.

Exhibition Photos



Our Certificates



FAQ

Q: Si j'ai besoin d'un devis, de quelles informations avons-nous besoin?

A: matériaux des vannes, température, pression, milieu, système d'application.

Q: Pouvez-vous fournir des actionneurs, que possédez-vous?

A: Électrovannes pneumatiques, électriques et hydrauliques. Les actionneurs RKSfluid adoptent la technologie américaine. Ce dont vous avez besoin, dites-le-nous.

Q: Quelle est votre capacité de production?

R: RKSfluid possède quatre usines qui peuvent fournir les produits dont vous avez besoin.

Q: délai de production

R: Les produits normaux sont disponibles en 2 à 5 jours ouvrables. Base personnalisée pour vos besoins.

Q: MOQ

A: 1 pc pour tous les produits.

Q: qu'en est-il de l'assurance qualité?

Un: 100% test de qualité avant la livraison, 2 ans de garantie. Assurer la sécurité de fonctionnement du système.

Nous avons obtenu la certification TUV, API, WRAS, CE, ISO.

Norme conforme à DIN, ASME, BS EN, JIS, API, AWWA.

Q: Comment pouvons-nous fournir un service de qualité à nos clients?

R: RKSfluid a 20 ans d'expérience et plus de 70 ingénieurs R&D fournissent un support technique, un choix de modèle et un guide d'installation.