

**RKSfluid®**



RKSfluid

**RKSfluid®**



RKSfluid

**RKSfluid®**



**RKSfluid®**



**RKSfluid®**



**RKSfluid®**



## DESIGN FEATURES

### DURABLE

- No-pin connection, 1 pc blow-out proof stem
- DI/CI Nodularity over 95%

### ANTI-CORROSION

- Material: Epoxy powder:  , Earth Best!
- Coating Thickness: 200-250µm
- Spraying temp: over 200°C. Doesn't fade, even wipe with diethyl ether

### QUALITY STANDARD

- 100% quality test, follow DIN, ASTM, JIS, GB/T, ISO, BS EN, API
- ONLY ONE Manufacturer get CE certification up to DN1800
- 2 years warranty. 15000 times On-off test, 30000 times Destructive experiment



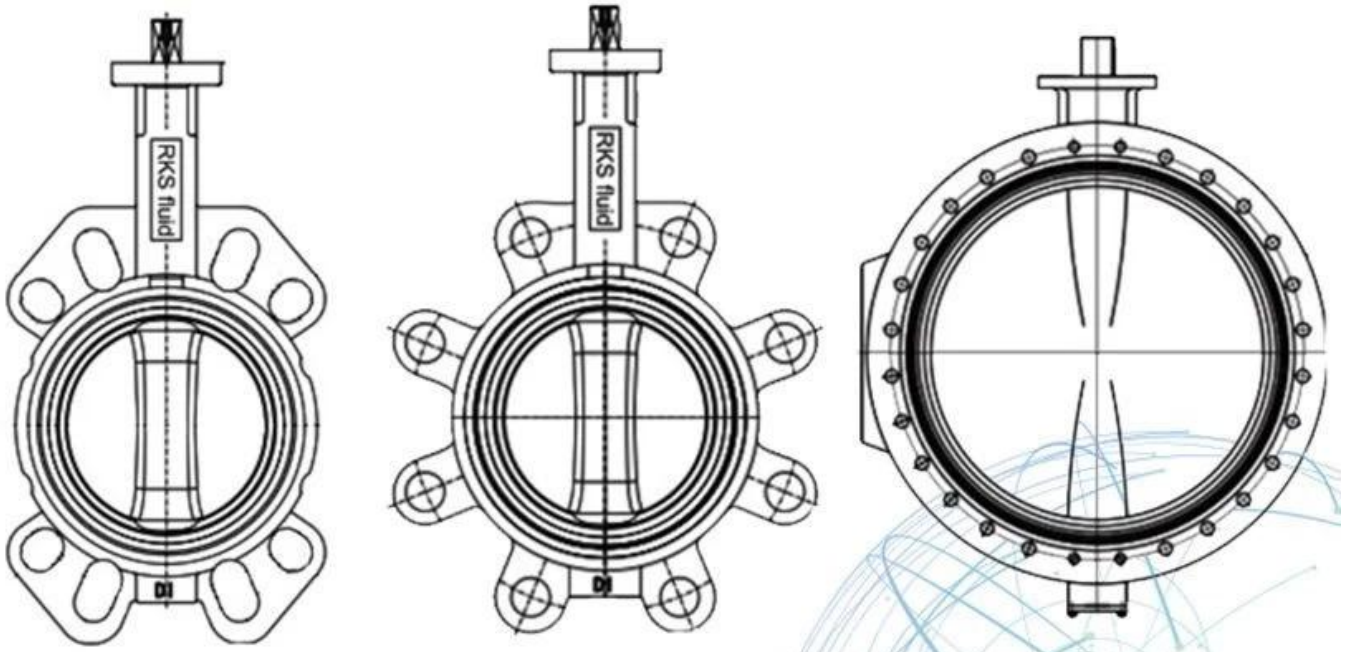

## APPLICATION SCENARIO



Industrial water application



Power plant



Sea water desalination



Water treatment



Water supply and drainage



HAVC



Food and drug



Water transport





# Our Factory



I Business area: fluid control products, technology and products for environmental protection.

II Advanced CNC machining centers, professional process cells, wide-range welding equipment, automatic assembly and coating lines.

III China's standard reference unit, to participate in the development of relevant valve industry standards.

IV We have set up a research and development center in Houston, Texas, in the United States.

V Product Standard: GB, German Standard, American Standard, TUV CE, ISO 9001, ADWO-2000, TS, PED, WRC WRAS, KTW, API 6D, API609.

VI Main Production: Butterfly Valve, Ball Valve, Gate Valve, Check Valve, Globe Valve, Pipe Fittings, Manual/Pneumatic/Electric Actuator, Valve Parts.

## Exhibition Photos



## Our Certificates



