



## DESIGN FEATURES

### DURABLE

- No-pin connection, 1 pc blow-out proof stem
- DI/CI Nodularity over 95%

### ANTI-CORROSION

- Material: Epoxy powder:  Earth Best!
- Coating Thickness: 200-250µm
- Spraying temp: over 200°C. Doesn't fade, even wipe with diethyl ether

### QUALITY STANDARD

- 100% quality test, follow DIN, ASTM, JIS, GB/T, ISO, BS EN, API
- ONLY ONE Manufacturer get CE certification up to DN1800
- 2 years warranty. 15000 times On-off test, 30000 times Destructive experiment

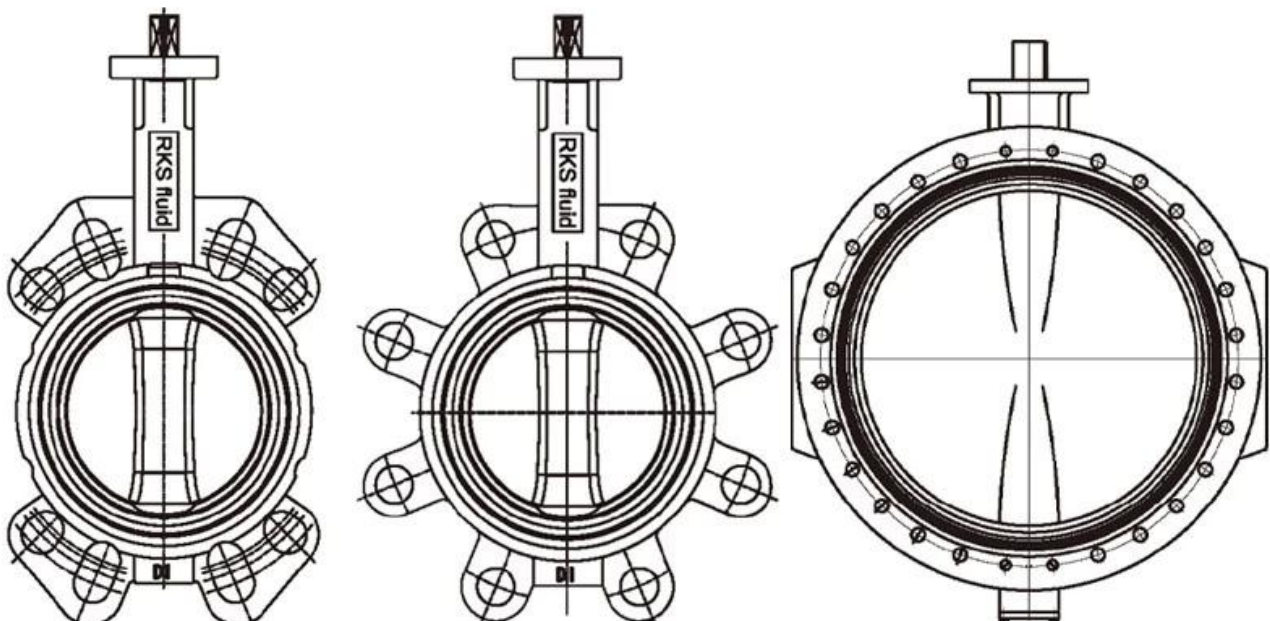

# APPLICATION SCENARIO



Industrial water application



Power plant



Sea water desalination



Water treatment



Water supply and drainage



HAVC



Food and drug



Water transport



# COMPANY FACTORY



## COMPANY INFORMATION

---



I Business area: fluid control products, technology and environmental protection products.

II Advanced CNC machining centers, professional process cells, wide-range welding equipment, automatic assembly lines and coating.

III China's standard reference unit, to participate in the development of relevant valve industry standards.

IV We have set up a research and development center in Houston, Texas, in the United States.

V Product Standard: GB, German Standard, American Standard, TUV CE, ISO 9001, ADWO-2000, TS, PED, WRC WRAS, KTW, API 6D, API609.

VI Main production: [butterfly valve](#), ball valve, gate valve, check valve, globe valves, pipe fittings, manual / pneumatic / electric actuator, valve parts.



## COMPANY QUALIFICATION



## COMPANY EXHIBITION



### FAQ:

**Q: If I need quotation, what informations do we need?**

A: Valves' materials, Temperature, Pressure, Medium, Appllction System.

**Q: Can you provide actuators, what you have?**

A: Pneumatic, Electric, Hrdraulic, Solenoid Valves. RKSfluid actuators adopt USA technology. Which you need, just tell us.

**Q: What's your productive capacity?**

A: RKSfluid has four plants that can provide the products you need.

**Q: Production lead time**

A: Normal products have stock in 2~5 working days. Customized base on your need.

**Q: MOQ**

A: 1pc for all products.

**Q: How about the quality assurance?**

A: 100% quality test before delivery, 2 years warranty. Ensure your system working safety.  
We got TUV, API, WRAS, CE, ISO certification.  
Standard conform to DIN, ASME, BS EN, JIS, API, AWWA.

**Q: How could you provide quality service to our customers?**

A: RKSfluid own 20 years experiences and more than 70 R&D engineers provide technical

support, model selection and installation guidance for you.