



# RKSfluid®

A key Valve in Flow Control



Butterfly Valve



Ball Valve



Gate Valve



Globe Valve

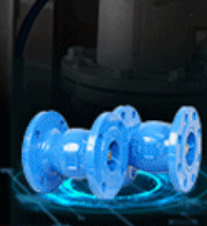

Check Valve



Pipe Fittings

## DESIGN FEATURES

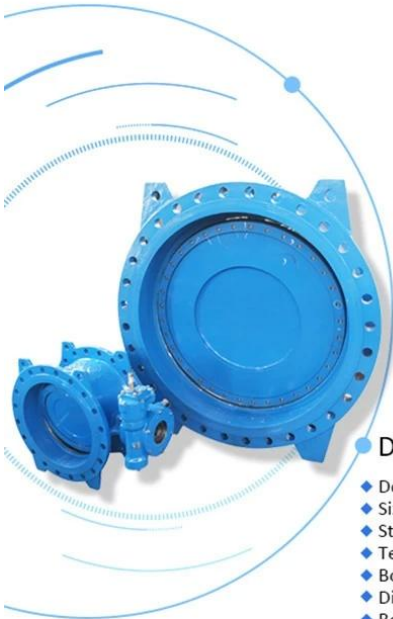

SPECIFICATION		
Nominal pressure (MPa)	1.6	
Testing pressure(MPa)	Seal	2.4
	Shell	1.76
Working pressure (MPa)	1.6	
Suitable temperature (°c)	<80°c	
Suitable medium	Water	

TECHNICAL REQUIREMENT	
1.Face to face standard: EN 558 Series 14.	
2.Flanges standard: BS EN1092-2:1997 PN16.	
3.Tests standard: BS EN12266-1:2003 Part 1 Rate A.	

### DESCRIPTION :

- ◆ Double Flange Eccentric Resilient Seated Butterfly Valve
- ◆ Size Range DN100-DN3000
- ◆ Standard - ISO / BS / DIN / AWWA /API
- ◆ Tests Standard - BS EN 12266-1
- ◆ Body - Ductile Iron / Cast Iron /Stainless Steel / WCB
- ◆ Disc - Ductile Iron / Cast Iron / Stainless Steel / WCB
- ◆ Body Ring -SS420 / SS304 / SS316
- ◆ Retaining Ring - SS420 / SS304 / SS316
- ◆ Disc Ring -EPDM
- ◆ Shaft - SS420 / SS431 / SS316
- ◆ Fusion Bonded Epoxy Coating - Min 300 Microns

The designs, material and specifications shown are subject to change without notice due to our continuing programme of product development.

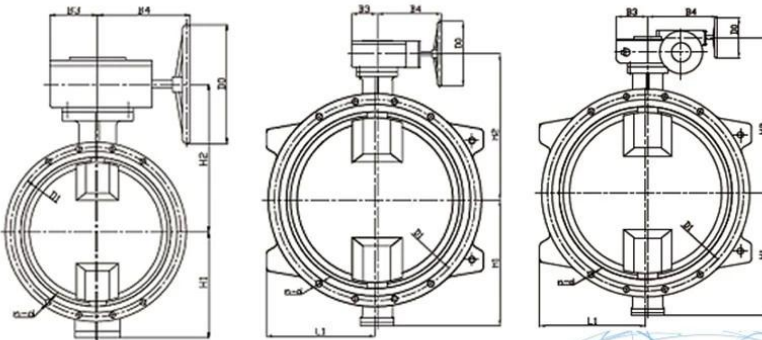

DN100-DN600

DN700-DN800

DN900-DN3000

## APPLICATION SCENARIO



# Our Factory



RKS fluid was founded in 1997. We are a production workshop for both foundry and machining, research & development center, and quality inspection center. The manufacturing facilities include CNC machining centers, professional processing cells, broad spectrum welding equipment, automatic assembling and coating lines. We have built a team for design, research & development. Our new testing center as a public service platform testing center in Liaoning

Province, Become the standard GB of the Chinese valve reference unit, to participate in the development of the relevant valve industry standards. In order to accelerate the expansion of overseas business and resources integration, and to support the success of RKS fluid sales in the USA, German, Russia. We have US Agent. Our product design standards cover: GB, ISO, German and American Standard, approved by TUV for CE and ADWO- 2000, ISO9001, TS, API. Our products: Manual, Pneumatically & electrically operated Ball valves, Butterfly valves and Gate Valves. Check Valves, Automatic Control Valves. Castings and Fittings: Valve bodies, Bonnets, Discs, Stems, Gear Box, Universal Couplings, Flange Adaptors, Tapping Saddles. After years of development, we continue to improve and seek out innovation while adhering to "Proven Technology, Superior Features and Legendary Value" as our product value philosophy. Customer satisfaction is our working goal!

## Our Certificates



## Exhibition Photos

