

DESIGN FEATURES

FEATURES

1. Fully Bore with seat diameter as DN+2 mm
2. Stable working even if the flow close to Zero
3. High performance and strength Nylon enforce diaphragm
4. One Million cycle test and 64 bar burst test

MAIN VALVE MATERIAL OPTION

- Ductile iron (DI): DN40-1200
- SUS304 (S3) or SUS316 (S6) or Duplex (SD) or Carbon Steel (CS) or Bronze (BR): DN40-400
- Aluminum (AL): DN40-200



Caratteristiche:

Fully bore globe pattern design, lowest head loss while fully open

Keep stable working condition even the flow rate close to zero

High sensitive and strength fabric reinforced diaphragm

- 1000000 cycles test between fully close and open with working pressure

- 5 times of working pressure destructive test

Most components are machined by CNC

Fusion bonded epoxy coating process is based on GSK & WIS standard

High standard production test

- Seal test: Low pressure 0.5 bar

High pressure 1.1xPN+1 bar

- Shell test: 1.5xPN+1 bar

- Pressure modulated vibration: +/-0.2 bar

Data collected automatically 1000 times/sec, display with static or dynamic chart

Easy installation, operation and free maintenance

Different materials with WRAS/KTW/NSF/FDA/ACS certification to meet different market

Size	DN40-DN1200
Working Medium	Water
Temperature	0°C~70°C
Material	Ductile Iron/Stainless Steel/Cast Steel/Bronze/Aluminum Alloy
Design Standards	CJ/T 219 & JB/T 10674 & EN 1074-5
Pressure Level	PN10, PN16, PN25
Stress Test Standard	GB/T 13927 & ISO 5208 & EN12266-1
Flange drilling standard	GB17241.6; EN1092-2; ISO7005-2; ANSI / JIS / AS2129
Structure Length	GB 12221 & EN558-1

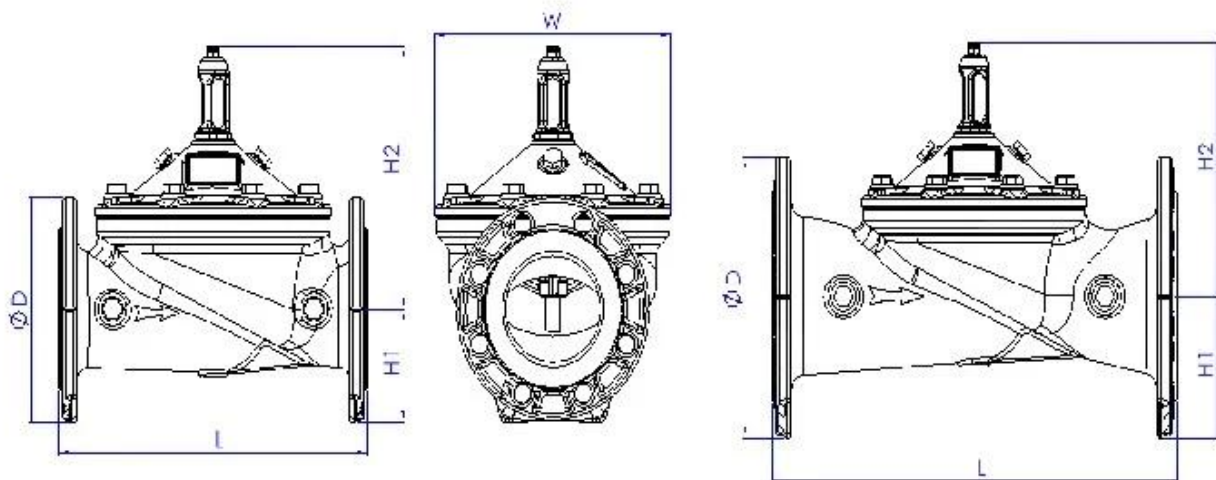

DN	L	H	H1	DN	L	H	H1
40	230	139	85	250	730	476	205
50	230	139	85	300	850	526	232
65	290	159	95	350	980	585	262
80	310	179	102	400	1100	624	292
100	350	214	112	500	1250	720	360
125	400	278	127	600	1450	835	425
150	480	333	145	800	1850	1110	515
200	600	407	172	1000	2250	1350	630

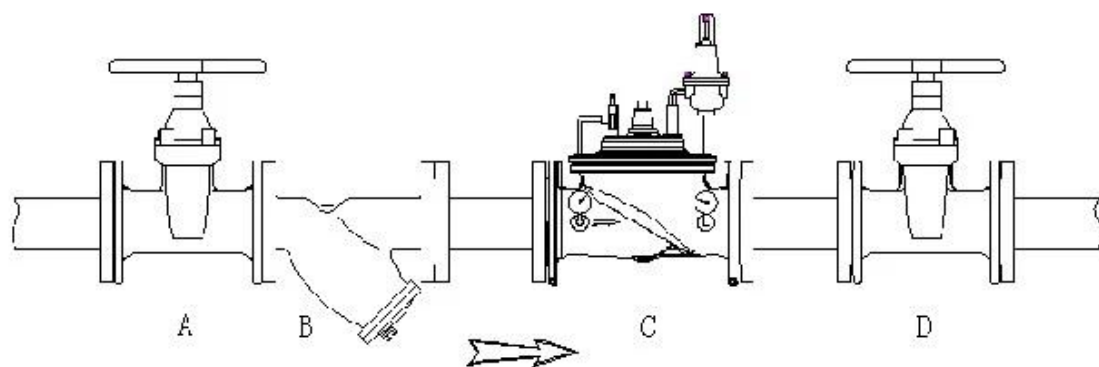

Area di applicazione

urban water supply and industrial/agricultural water transmission lines, etc.

Principio di funzionamento

pressure reducing valve is an accurate and pilot controlled valve. It can reduce a high inlet water pressure to a steady downstream pressure regardless of the inlet water pressure changing.



I AREA BUSINESS: Prodotti per il controllo del fluido, tecnologia e prodotti di protezione ambientale.

II Centri di lavorazione CNC avanzati, celle di processo professionali, apparecchi di saldatura ad ampio raggio, linee di assemblaggio automatico e rivestimento.

III Unità di riferimento standard della Cina, per partecipare allo sviluppo di norme del settore della valvola pertinenti.

IV Abbiamo creato un centro di ricerca e sviluppo a Houston, in Texas, negli Stati Uniti.

V Standard del prodotto: GB, standard tedesco, standard americano, TUV CE, ISO 9001, ADWO-2000, TS, PED, WRC WRAS, KTW, API 6D, API609.

VI Produzione principale: valvola a farfalla, valvola a sfera, valvola del cancello, valvola di ritegno, valvole globali, raccordi per tubi, attuatore manuale / pneumatico / elettrico, parti della valvola



Exhibition Photos



Our Certificates



FAQ

D: Se ho bisogno di quotazione, quali informazioni abbiamo bisogno?

A: materiali delle valvole, temperatura, pressione, sistema medio, implicazione.

D: Puoi fornire attuatori, cosa hai?

A: Valvole pneumatiche, elettriche, idrauliche, solenoide. Gli attuatori RKSfluid adottano la tecnologia USA. Di cui hai bisogno, dicci solo.

D: Qual è la tua capacità produttiva?

A: RKSfluid ha quattro piante in grado di fornire i prodotti necessari.

D: Tempo di consegna della produzione

A: I prodotti normali hanno scorte in 2 ~ 5 giorni lavorativi. Base personalizzata sul tuo bisogno.

D: MOQ.

A: 1pc per tutti i prodotti.

D: Che ne dici della garanzia della qualità?

A: Test di qualità al 100% prima della consegna, 2 anni di garanzia. Assicurati la sicurezza del

tuo sistema.

Abbiamo ottenuto la certificazione TUV, API, WRAS, CE, ISO.

Standard conforme a DIN, ASME, BS EN, JIS, API, AWWA.

D: Come potete fornire un servizio di qualità ai nostri clienti?

A: RKSfluid possiede 20 anni di esperienze e oltre 70 ingegneri di ricerca e sviluppo forniscono supporto tecnico, selezione del modello e guida di installazione per voi.