



RKSfluid®

A key Valve in Flow Control



Butterfly Valve



Ball Valve



Gate Valve



Globe Valve

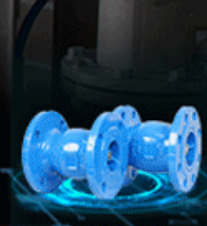

Check Valve



Pipe Fittings

DESIGN FEATURES

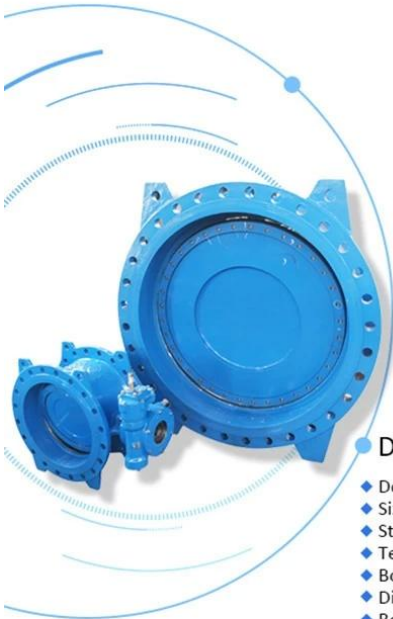

SPECIFICATION		
Nominal pressure (MPa)	1.6	
Testing pressure(MPa)	Seal	2.4
	Shell	1.76
Working pressure (MPa)	1.6	
Suitable temperature (°c)	<80°c	
Suitable medium	Water	

TECHNICAL REQUIREMENT	
1.Face to face standard: EN 558 Series 14.	
2.Flanges standard: BS EN1092-2:1997 PN16.	
3.Tests standard: BS EN12266-1:2003 Part 1 Rate A.	

DESCRIPTION :

- ◆ Double Flange Eccentric Resilient Seated Butterfly Valve
- ◆ Size Range DN100-DN3000
- ◆ Standard - ISO / BS / DIN / AWWA /API
- ◆ Tests Standard - BS EN 12266-1
- ◆ Body - Ductile Iron / Cast Iron /Stainless Steel / WCB
- ◆ Disc - Ductile Iron / Cast Iron / Stainless Steel / WCB
- ◆ Body Ring -SS420 / SS304 / SS316
- ◆ Retaining Ring - SS420 / SS304 / SS316
- ◆ Disc Ring -EPDM
- ◆ Shaft - SS420 / SS431 / SS316
- ◆ Fusion Bonded Epoxy Coating - Min 300 Microns

The designs, material and specifications shown are subject to change without notice due to our continuing programme of product development.

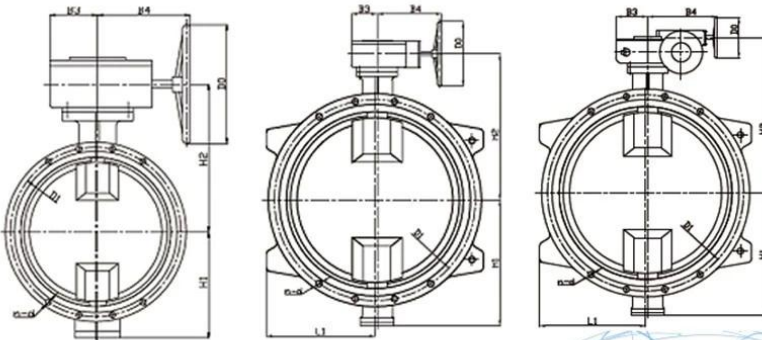

DN100-DN600

DN700-DN800

DN900-DN3000

APPLICATION SCENARIO



Our Factory



Il fluido RKS è stato fondato nel 1997. Siamo un laboratorio di produzione sia per fonderia e lavorazione meccanica, centro di ricerca e sviluppo e centro di controllo qualità. Gli impianti di produzione comprendono centri di lavoro a controllo numerico, celle di lavorazione professionali, attrezzature per saldatura ad ampio spettro, linee di assemblaggio e rivestimento automatiche. Abbiamo creato un team per progettazione, ricerca e sviluppo. Il nostro nuovo centro di

collaudo come centro di collaudo di piattaforme di servizio pubblico nella provincia di Liaoning, diventa il GB standard dell'unità di riferimento cinese per valvole, per partecipare allo sviluppo dei relativi standard del settore delle valvole. Al fine di accelerare l'espansione dell'integrazione commerciale e delle risorse all'estero e supportare il successo delle vendite fluide di RKS negli Stati Uniti, in Germania, in Russia. Abbiamo un agente americano. I nostri standard di progettazione del prodotto riguardano: GB, ISO, standard tedesco e americano, approvati da TUV per CE e ADWO- 2000, ISO9001, TS, API. I nostri prodotti: valvole a sfera manuali, pneumatiche ed elettriche, valvole a farfalla e valvole a saracinesca. Valvole di ritegno, valvole di controllo automatico. Pezzi fusi e raccordi: corpi valvola, cofani, dischi, steli, scatola ingranaggi, giunti universali, adattatori di flangia, tappi a sella. Dopo anni di sviluppo, continuiamo a migliorare e cercare innovazione, aderendo a "Tecnologia comprovata, caratteristiche superiori e valore leggendario "come la nostra filosofia di valore del prodotto. La soddisfazione del cliente è il nostro obiettivo lavorativo!

Our Certificates



Exhibition Photos

