

## DESIGN FEATURES



### Features



- Use AkzoNobel material.
- Super Anti-corrosion
- Epoxy powder coating 200-250um,
- Baking varnish over 200°C,

NO.		
1	Body	GGG50
2	Dise	GGG40+EPDM
3	Wedge nut	C48600
4	Stem	SS431
5	Bonnet	GT450-10
6	Gasket	EPDM
7	Y-ring	EPDM85-90
8	Fix ring	CuZn21Si3/C69300
9	Thrust bearing	C69300
10	Seal ring	EPDM70
11	O ring	NBR
12	Retainer ring	POM
13	Bushing ring	POM
14	Gland	SS431
15	Dustproof ring	EPDM85
16	Dise core	GGG40
17	Bolt	SS316

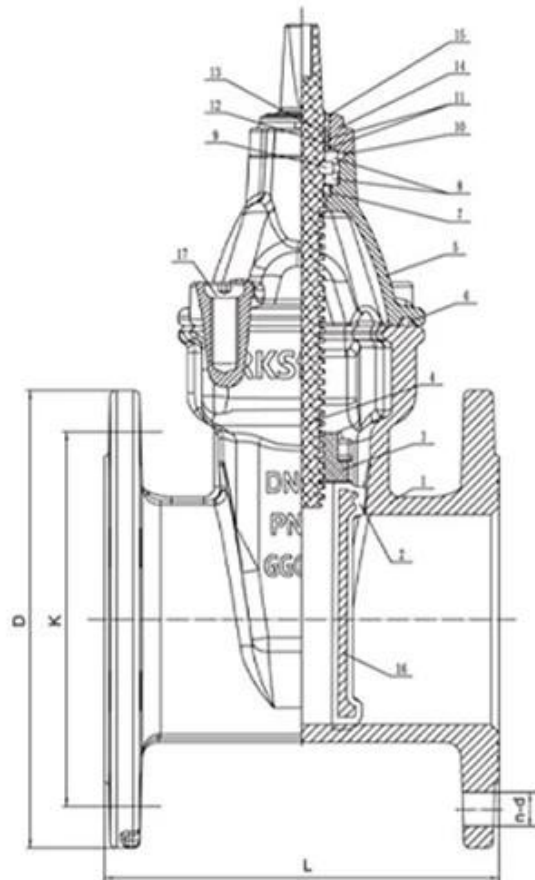



Free wedge nut, **reduces the stem bending forces** and at the same time enables it to be easily replaced.



The more compact new cap, **reduces the water retention areas** in order to reduce the risk of bacterial growth.



One piece stainless steel stem in for **better resistance to axial load** and to with stand higher operating torques.



**Three locking tab** for bayonet system prevents self-dismantling.



Dust guard integrating three O-ring shape, **prohibiting the introduction of foreign bodies** at the stem.



**Male guiding system with composite sliding skate** reduces the wear of the wedge against the body, allowing a smooth functionality and a longer life time of the valve.



**Triple seal at the operating stem** to ensure tightness with the test of time (2500 cycles).



**New male composite sliding skate technology** ensuring a low operating torque even under high differential pressure and preventing damage or corrosion generated by the friction.

## RELATED PRODUCTS

---



# APPLICATION SCENARIO



Industrial water application



Power plant



Sea water desalination



Water treatment



Water supply and drainage



HAVC



Food and drug



Water transport





## COMPANY INFORMATION



I Area di business: prodotti per il controllo dei fluidi, prodotti tecnologici e di protezione ambientale.

II Centri di lavorazione CNC avanzati, celle di processo professionale, apparecchiature di saldatura ad ampio raggio, linee di montaggio automatico e rivestimento.

III Unità di riferimento standard della Cina, per partecipare allo sviluppo degli standard del settore delle valvole pertinenti.

IV Abbiamo istituito un centro di ricerca e sviluppo a Houston, in Texas, negli Stati Uniti.

V Standard di prodotto: GB, standard tedesco, standard americano, TUV CE, ISO 9001, ADWO-2000, TS, PED, WRC WRAS, KTW, API 6D, API609.

VI Produzione principale: valvola a farfalla, valvola a sfera, valvola del cancello, valvola di ritegno, valvole a globo, raccordi per tubi, attuatore manuale / pneumatico / elettrico, parti della valvola.

# COMPANY FACTORY





# COMPANY QUALIFICATION



## COMPANY EXHIBITION



### FAQ

**D: Se ho bisogno di citazione, quali informazioni abbiamo bisogno?**

A: Materiali delle valvole, temperatura, pressione, mezzo, sistema di applicazione.

**D: Puoi fornire attuatori, cosa hai?**

A: valvole pneumatiche, elettriche, idrauliche, solenoidi. Gli attuatori RKSfluid adottano la tecnologia USA. Di cui hai bisogno, solo dicendoci.

**D: Qual è la tua capacità produttiva?**

A: RKSfluid ha quattro piante in grado di fornire i prodotti di cui hai bisogno.

**D: Tempo di consegna della produzione**

A: I prodotti normali hanno scorte in 2 ~ 5 giorni lavorativi. Base personalizzata sulla tua necessità.

**D: Moq**

A: 1pc per tutti i prodotti.

**D: E la garanzia della qualità?**

A: Test di qualità al 100% prima della consegna, 2 anni di garanzia. Assicurati che il tuo sistema funzioni sicurezza.

Abbiamo ottenuto TUV, API, WRAS, CE, certificazione ISO.

Standard è conforme a Din, Asme, BS EN, JIS, API, AWWA.

D: Come potresti fornire un servizio di qualità ai nostri clienti?



A: RKSfluid Own 20 anni di esperienze e più di 70 ingegneri di R&S forniscono supporto tecnico, selezione dei modelli e indicazioni di installazione per te.