

RKSfluid®

Proven Technology-Superior Features-
Legendary Value

KARX-Combination Kinetic Air Release Valve

NPS1-NPS12 (DN25-DN300)



KARX-Combination Kinetic Air Release Valve

KARX- Combination kinetic air release valve provide 3 functions: 1.Large air release during filling of the pipeline. 2.Small air release under pressurized pipeline. 3.Large air intake during draining of the pipeline.

Features:

- Advanced design with simple mechanism, strong float to prevent cracking during sudden water hammer& quick closure.
- Aero kinetic mechanism to resist blow shut under higher air velocity even up to sonic velocity of air.
- No arms or levers to prevent vibrating, bending, direct closure of the float.
- Smooth cage outside of the float, keep float moving in specified guide rail.
- Bottom rubber buffer for collision prevention, and drain easy with proper holes around the cage during vacuum.
- Outside screen will be an option for safety and prevent insects or birds in.
- Fully fusion epoxy coated inside and outside of valve body for long term services.
- Manufacturing standard meets BS EN 1074-4, AWWA C512
- Flange drilling and dimension meets BS EN 1092 and BS EN 558 and ANSI flange.



Service Fields:

For water system, fire fighting, irrigation system.

Technical Data:

Size range: DN 25-300MM
Pressure ratings: 1.0Mpa, 1.6Mpa(Thread)
1.0Mpa, 1.6Mpa, 2.5 Mpa(Flange)
Working temperature: -10°-80°C.
Flow media: clean water

Main Valve-DN50-DN300 Parts List

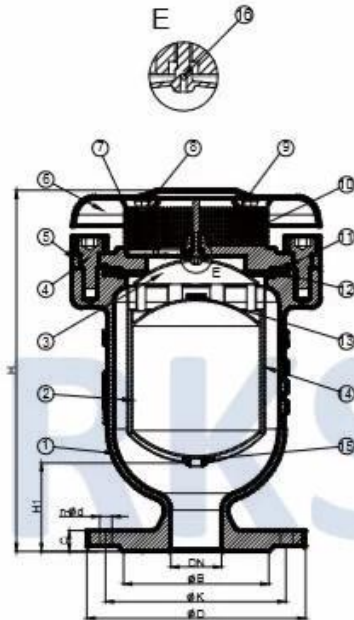

No.	Part Name	Material	Standard
1	Body	Ductile Iron	EN GJS 500-7
2	Float	Stainless Steel	AISI 304
3	Sealing Arc	Stainless Steel	AISI 304
4	In Hex Bolt	Carbon Steen/ Stainless Steel	G. I/ AISI 304
5	Bonnet	Ductile Iron	EN GJS 500-7
6	Cover	Carbon Steel	AISI 304
7	Screen	Stainless Steel	AISI 304
8	Hex Bolt	Carbon Steen/ Stainless Steel	G. I/ AISI 304
9	Washer	Stainless Steel	AISI 304
*10	Pillar	Aluminum	Commercial
11	O-ring	Rubber	NBR/EPDM
12	Seat	Rubber	NBR/EPDM
13	Nozzle Seat	Rubber	NBR/EPDM
14	Guide Barrel	Stainless Steel	AISI 304
15	Buffer	Rubber	NBR/EPDM
16	Small Nozzle	Stainless Steel	AISI 304

*: For Size ≤DN150.

Dimension

		Unit: MM												
		ØB			ØD			ØK			H	N-Ød		
DN	Model No.	PN10	PN16	PN25	PN10	PN16	PN25	PN10	PN16	PN25		PN10	PN16	PN25
50	KARX-0050	99	99	99	165	165	165	125	125	125	280	4-Ø19	4-Ø19	4-Ø19
80	KARX-0080	132	132	132	200	200	200	160	160	160	362	8-Ø19	8-Ø19	8-Ø19
100	KARX-0100	156	156	156	220	220	235	180	180	190	395	8-Ø19	8-Ø19	8-Ø23
150	KARX-0150	211	211	211	285	285	300	240	240	250	485	8-Ø23	8-Ø23	8-Ø28
200	KARX-0200	266	266	274	340	340	360	295	295	310	582	8-Ø23	12-Ø23	12-Ø28
300	KARX-0300	370	370	389	445	460	485	400	410	430	750	12-Ø23	12-Ø28	16-Ø31

Descrizione

1. Design avanzato con meccanismo semplice, galleggiante resistente per evitare crepe durante improvvisi colpi d'ariete e chiusura rapida.
2. Meccanismo aerocinetico per resistere al soffio a velocità dell'aria più elevata fino alla velocità del suono dell'aria.
3. Tampone di gomma inferiore per prevenire le collisioni e drenare facilmente con i fori adeguati intorno alla gabbia durante il vuoto. Schermo esterno sarà un'opzione per la sicurezza e la prevenzione di insetti o uccelli.
4. Nessun braccio o leva per impedire la vibrazione, la flessione, la chiusura diretta del galleggiante. Gabbia liscia fuori dal galleggiante, mantenere galleggiante muoversi nella guida di guida specificata.
5. Rispettare la norma BS EN 1074-4.

