



RKSfluid®

A key Valve in Flow Control



Butterfly Valve



Ball Valve



Gate Valve



Globe Valve



Check Valve



Pipe Fittings

DESIGN FEATURES

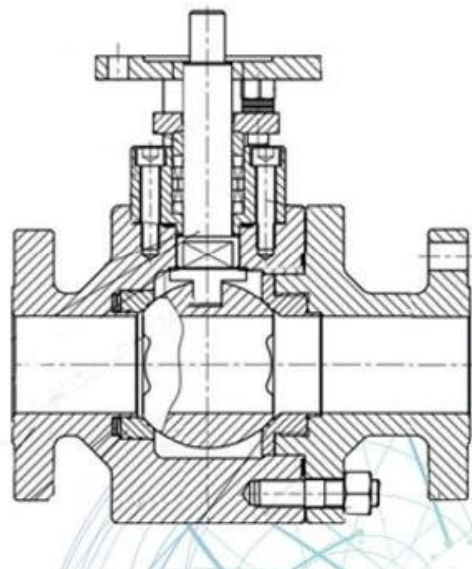
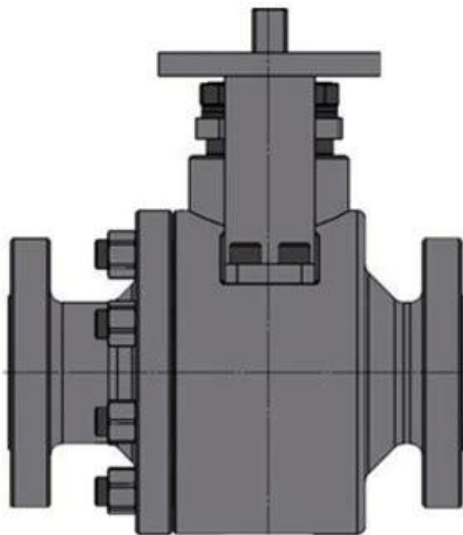

APPLICATION SCENARIO



Industrial water application



Power plant



Petroleum



Steel



Wastewater treatment



Acid-base



Healing drugs



Refined coal



Our Factory



Company Advantages



I 21 years of professional experience

II 4 factories

III Independent research and development team
28 top senior professional researchers

IV 2 professional testing centers

V 100% high level ex-factory inspection

VI High quality imported materials

VII 2 years quality assurance, repair and replacement

GB 150 TUV CE ISO 9001 ADWO-2000 TS PED WRC WRAS KTW API 6D API 609

