





Air Release valve

Size range:DN25-DN300

Pressure ratings:PN10 PN16

Body:Ductile Iron

Trim:SS304 SS316 etc

Connection:ARVS/KARS-BPT threaded, KARX-Flanged

Working temperature: -10°C~+80°C

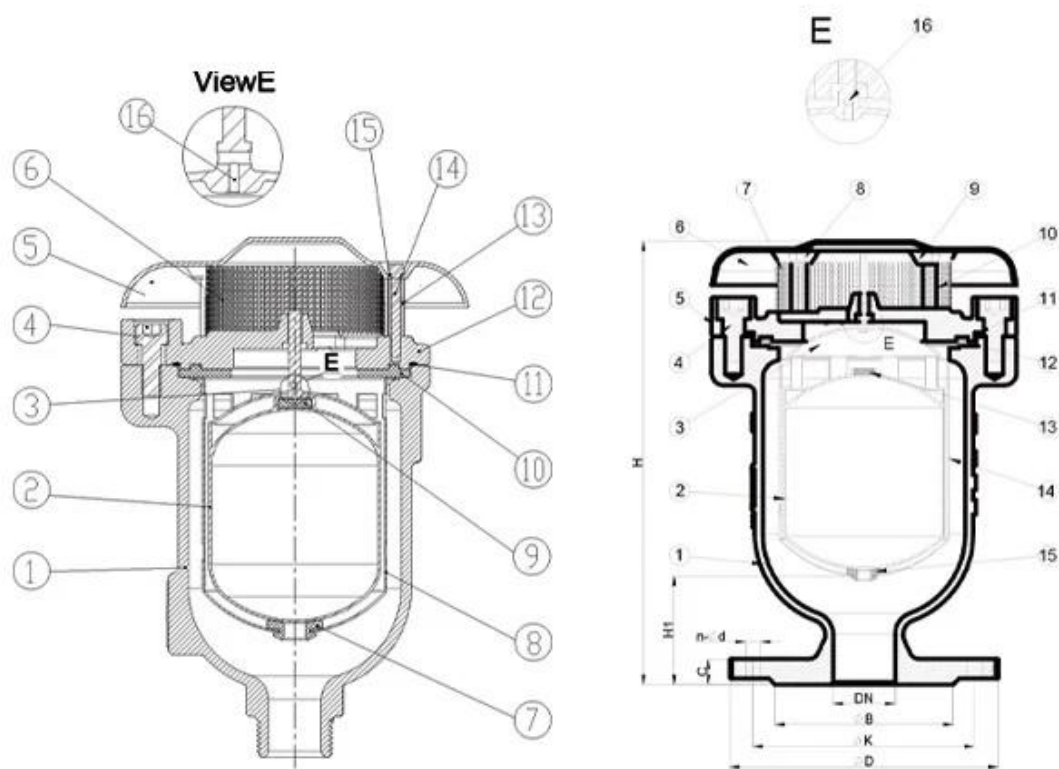

DN25-DN50

DN50-DN300

1. 2. 3. 4. 5. BS EN 1074-4

COMPANY INFORMATION



RKSfluid 於1997年創立，是一家專業從事液壓系統設計、製造、安裝、維修及保養的企業。公司擁有先進的CNC加工設備，採用優質材料，確保產品的高精度和耐用性。公司產品廣泛應用於各種工業領域，如礦山、建築、機械、船舶等。公司秉承「誠信、專業、服務」的宗旨，為客戶提供優質的液壓系統解決方案。公司產品符合GB、ISO、CE、ADWO-2000、TUV、ISO9001、TS、API等國際標準。公司設有研發中心，不斷研發新產品，提高產品競爭力。公司設有銷售部、技術部、生產部、質量部、倉庫部等部門，為客戶提供全方位服務。公司設有分公司，覆蓋全國各地。公司產品銷路廣泛，深受客戶信賴。公司將繼續秉承「誠信、專業、服務」的宗旨，為客戶提供優質的液壓系統解決方案。

COMPANY FACTORY



- I
- II CNC
- III
- IV

V GB TUV CE ISO 9001 ADWO-2000 TS PED WRC WRAS KTW API 6D API609

VI



COMPANY QUALIFICATION



COMPANY EXHIBITION



Q:

A:

MOQ:

MOQ: 1

Q:

A: 100% 2

TUV API WRAS CE ISO

DIN ASME BS EN JIS API AWWA

Q:

A: RKSfluid 20 70