

PRODUCT STRUCTURE

Features

- Size range DN100-1200mm
- Standard-ISO/ BS/DIN /AWWA/API
- Tests standard-BS EN 12266-1
- Body-Ductile Iron/Cast Iron/Stainless Steel/WCB
- Body Ring-SS420/SS304/SS316
- Disc Ring-EPDM
- Shaft-420/S5431/SS316
- Fusion bonded epoxy coating- Min 300 Microns

This series tilting check valves are suitable to be used at the exit of the pump whose medium is water. It is used to prevent or reduce medium back from water hammer. So it can protect the pipeline system. Suitable temperature $\leq 80^{\circ}\text{C}$

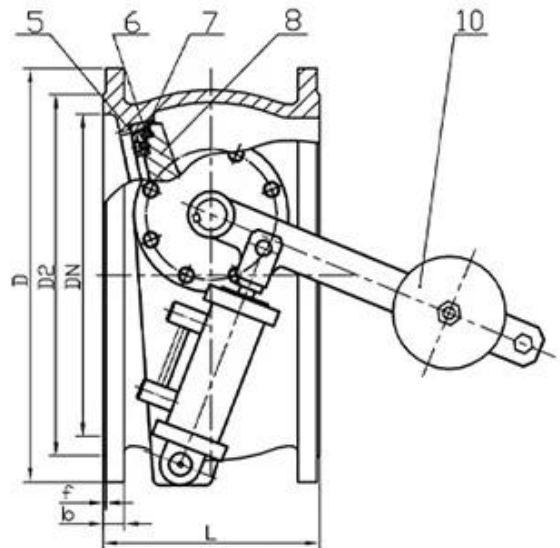
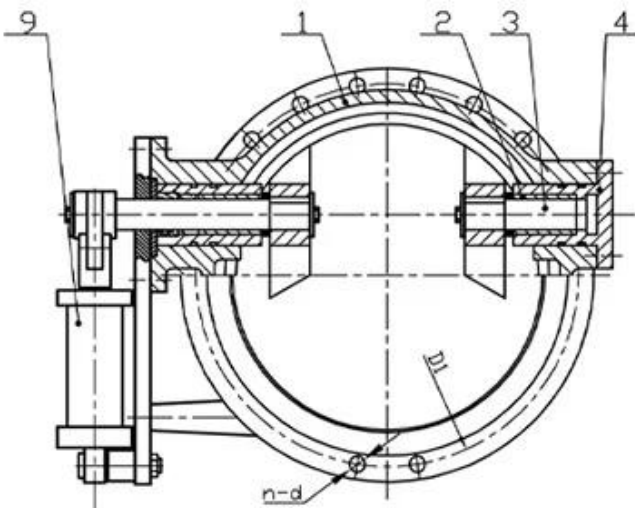

APPLICATION SCENARIO



Industrial water application



Power plant



Sea water desalination



Water treatment



Water supply and drainage



HAVC



Food and drug



Water transport



COMPANY FACTORY



COMPANY INFORMATION



I 公司位于中国浙江省宁波市北仑区

II 公司拥有 CNC 加工中心 和 数控车床 等先进设备

III 公司拥有专业的研发团队

IV 公司拥有完善的质量管理体系

V 公司拥有 GB、TUV CE、ISO 9001、ADWO-2000、TS、PED、WRC WRAS、KTW、API 6D、API609 等认证

VI 公司拥有完善的生产设备

01

21 years of professional experience

03

Independent research and development team
28 top senior professional researchers

05

100% high level ex-factory inspection

07

2 years quality assurance, repair and replacement

4 factories

02

2 professional testing centers

04

High quality imported materials

06

COMPANY QUALIFICATION



COMPANY EXHIBITION



Partners



A: RKSfluid 20 70