

PRODUCT STRUCTURE

Features

- Size range DN100-1200mm
- Standard-ISO/ BS/DIN /AWWA/API
- Tests standard-BS EN 12266-1
- Body-Ductile Iron/Cast Iron/Stainless Steel/WCB
- Body Ring-SS420/SS304/SS316
- Disc Ring-EPDM
- Shaft-420/S5431/SS316
- Fusion bonded epoxy coating- Min 300 Microns

This series tilting check valves are suitable to be used at the exit of the pump whose medium is water. It is used to prevent or reduce medium back from water hammer. So it can protect the pipeline system. Suitable temperature $\leq 80^{\circ}\text{C}$

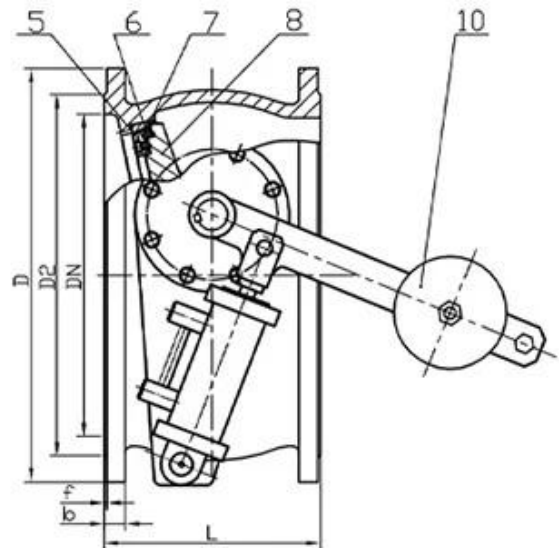
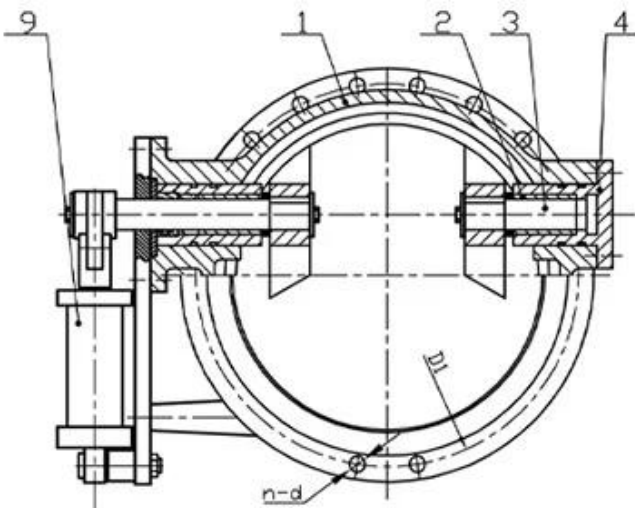

APPLICATION SCENARIO



Industrial water application



Power plant



Sea water desalination



Water treatment



Water supply and drainage



HAVC



Food and drug



Water transport



COMPANY FACTORY



Advanced CNC Machining Center

Professional Process Cells

China

Cention

GB American Standard Tuv CE ISO 9001 ADWO-2000 TS PED WRC WRA KTW API 6D API609

VI / /

COMPANY INFORMATION



COMPANY QUALIFICATION



COMPANY EXHIBITION



Partners



A RKSfluid 20 70 R D