



RKSfluid®

A key Valve in Flow Control



Butterfly Valve



Ball Valve



Gate Valve



Globe Valve



Check Valve



Pipe Fittings

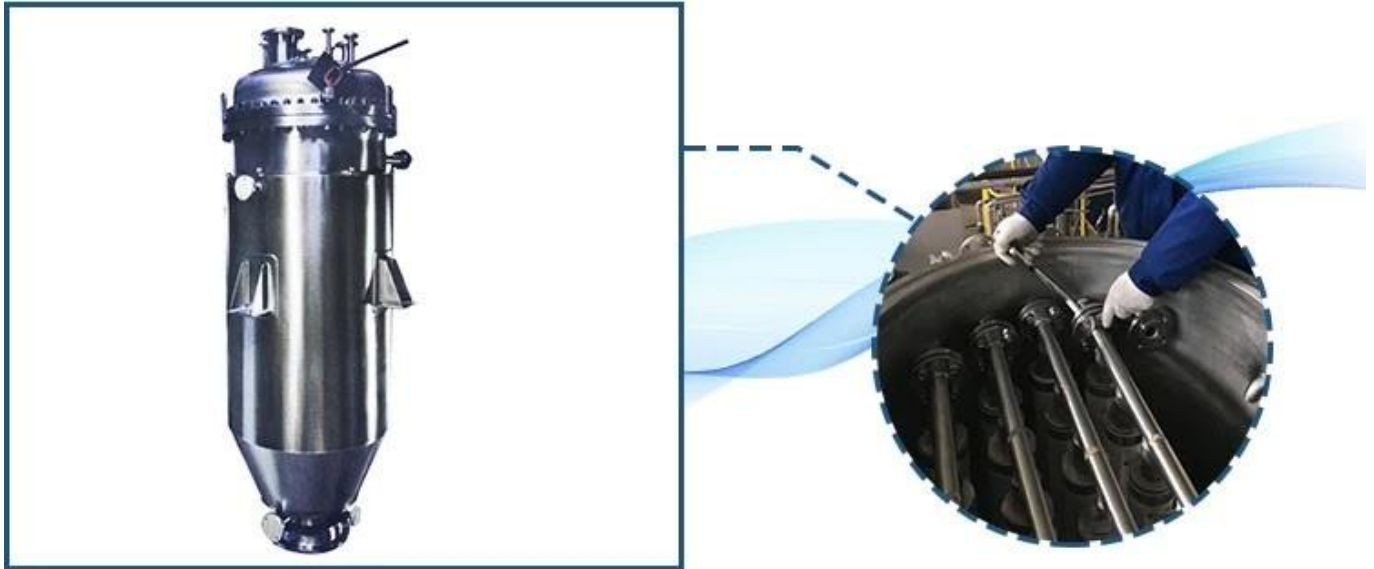

- Intelligent system, fully automatic sealing operation
- Seal zero leakage, unique structure easy for back flushing
- High efficiency by purified gas back washing
- High impurity content of filtration 0.1% ~ 50%
- Removable, porous wick, easy to replace, clean and maintain
- Designed for high production standard. Such as non-polluting food, biological products, medicine, fine chemistry, etc.

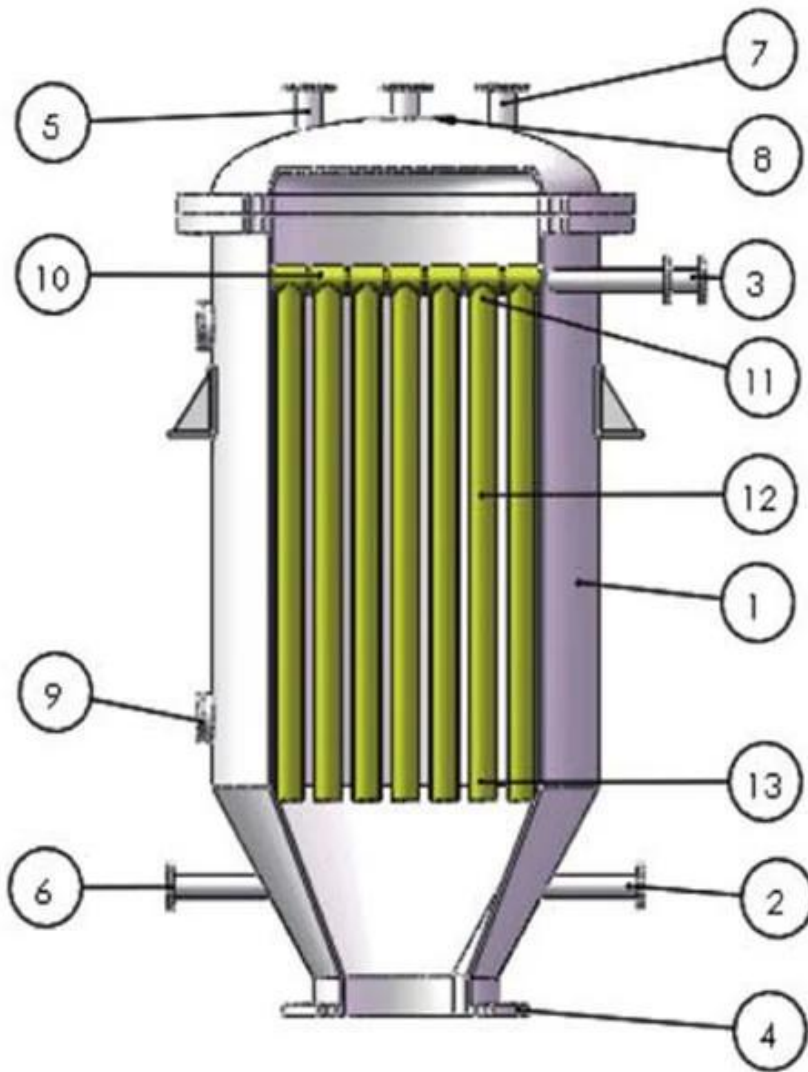

- 1, Pressure Vessel
- 2, Outlet
- 3, Outlet of clear liquid
- 4, Deslagging Port
- 5, Vent & Overflow port
- 6, Feed port
- 7, Connection port of instruments
- 8, Standby Port
- 9, Viewport
- 10, Liquid collection tube
- 11, Filtration unit
- 12, Filtration medium
- 13, Clamp for fixed the filter element

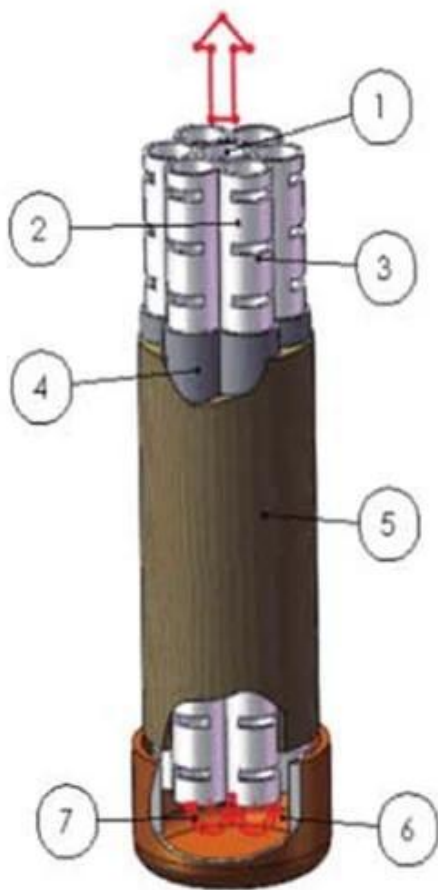

1. Central tube & Clear liquid collection tube
2. Filtration tube
3. A hole of filtration tube
4. Filtration medium
5. Filter cake
6. Collection chamber
(connect the centre tube and filtration tube)
7. Clear liquid
8. Backflush gas

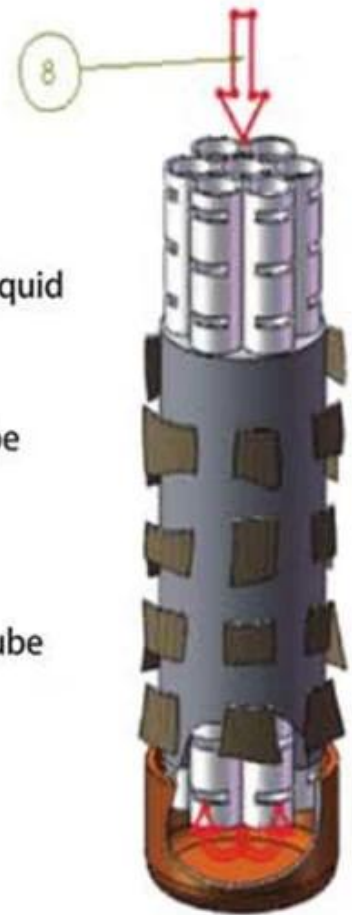

Our Factory



Company Advantages

01

21 years of professional experience

03

Independent research and development team
28 top senior professional researchers

05

100% high level ex-factory inspection

07

2 years quality assurance, repair and replacement

4 factories

02

2 professional testing centers

04

High quality imported materials

06



1. 公司拥有一流的生产设备，采用先进的PP材料，确保产品质量。
2. 公司拥有10年以上的设计和生产经验。
3. 公司符合API、AWWA、ASME、BS EN、DIN、JIS、TUV、CE、ISO9001、TS、OHSAS、WRAS等标准。
4. 公司拥有专业的R&D团队，提供定制化的产品和服务。

Q4MOQ

A4quality.We1pc

Q5

A5100

Q6

A6

Q7

A71