



RKSfluid®

A key Valve in Flow Control



Butterfly Valve

Ball Valve

Gate Valve

Globe Valve

Check Valve

Pipe Fittings

DN32/40~DN300

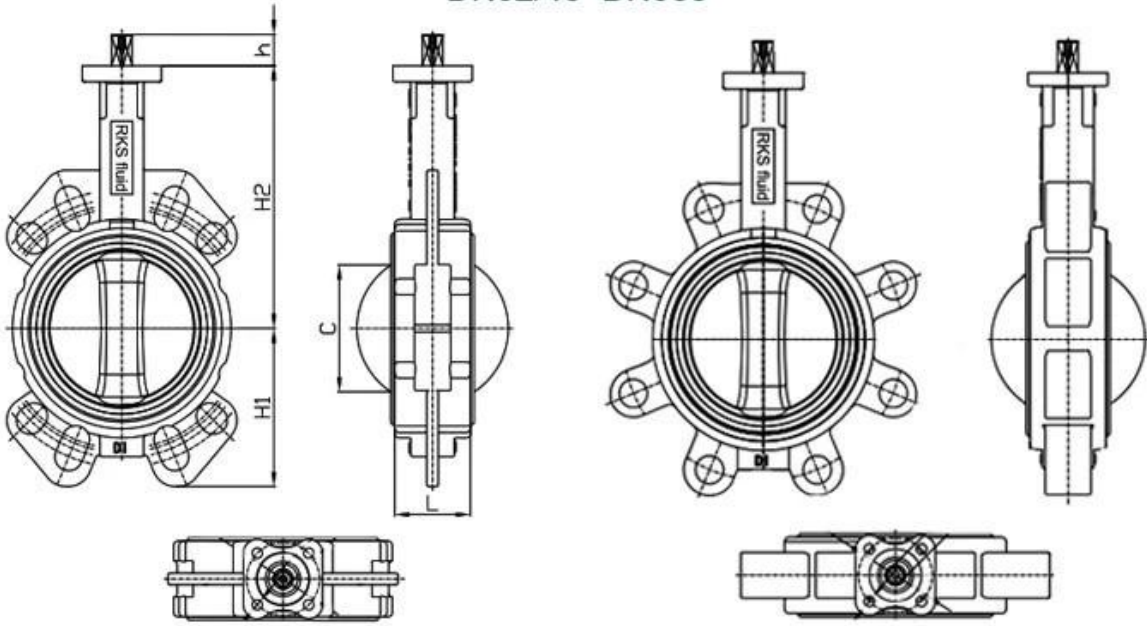

DN350~DN1000

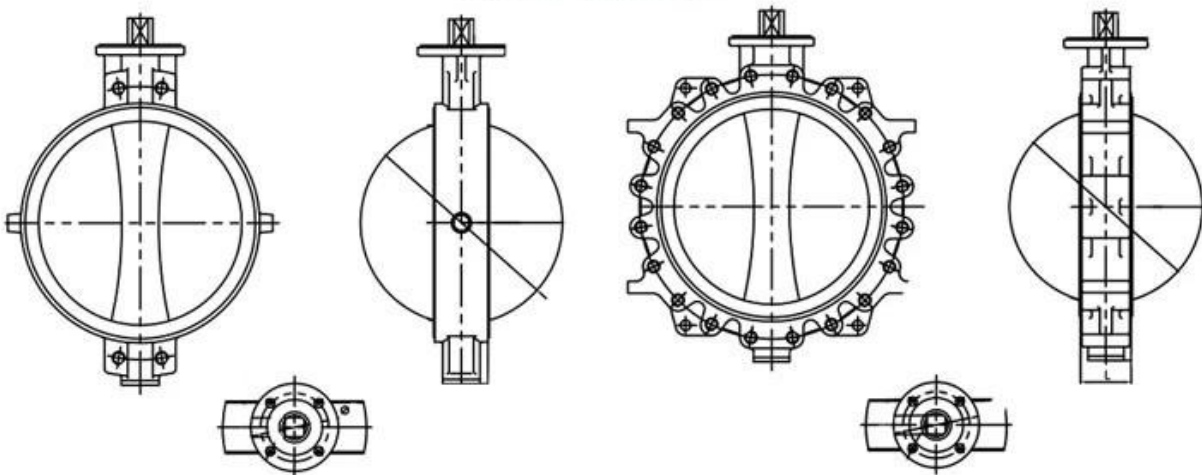

DN500~DN2400

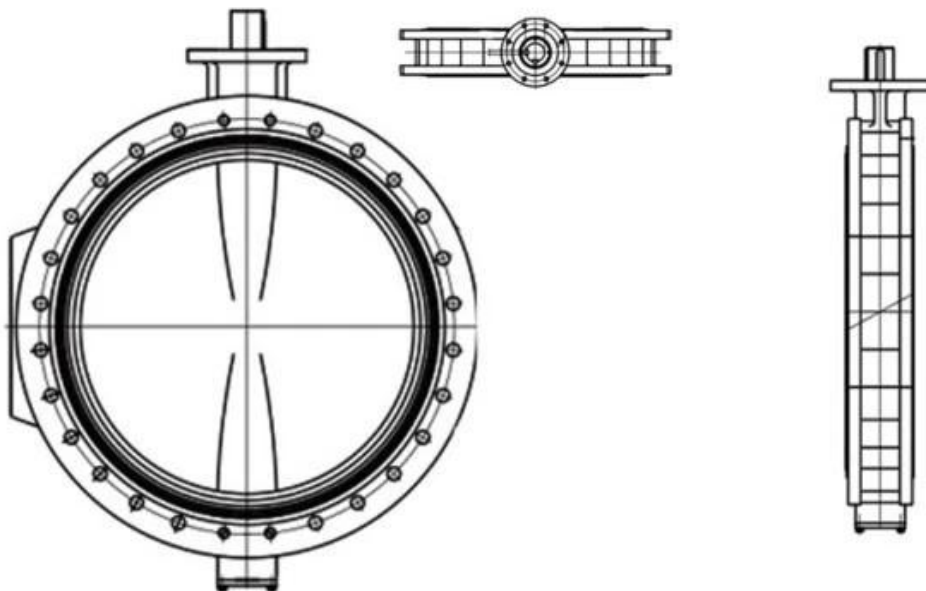

DESIGN FEATURES

DURABLE

- No-pin connection, 1 pc blow-out proof stem
- DI/CI Nodularity over 95%

ANTI-CORROSION

- Material: Epoxy powder:  , Earth Best!
- Coating Thickness: 200-250µm
- Spraying temp: over 200°C. Doesn't fade, even wipe with diethyl ether

QUALITY STANDARD

- 100% quality test, follow DIN, ASTM, JIS, GB/T, ISO, BS EN, API
- ONLY ONE Manufacturer get CE certification up to DN1800
- 2 years warranty. 15000 times On-off test, 30000 times Destructive experiment



APPLICATION SCENARIO



Industrial water application



Power plant



Sea water desalination



Water treatment



Water supply and drainage



HAVC



Food and drug



Water transport



Our Factory



Company Advantages

01

21 years of professional experience

03

Independent research and development team
28 top senior professional researchers

05

100% high level ex-factory inspection

07

2 years quality assurance, repair and replacement

4 factories

02

2 professional testing centers

04

High quality imported materials

06

Q MOQ

A 1

Q

A 100 2

TUV API WRAS ISO

DIN ASME BS EN JIS API AWWA

Q

A RKSfluid 20 70