



RKSfluid®

A key Valve in Flow Control



Butterfly Valve



Ball Valve



Gate Valve



Globe Valve



Check Valve



Pipe Fittings

DESIGN FEATURES

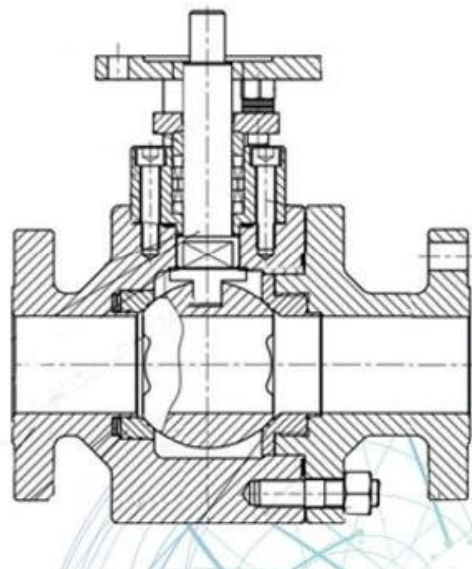
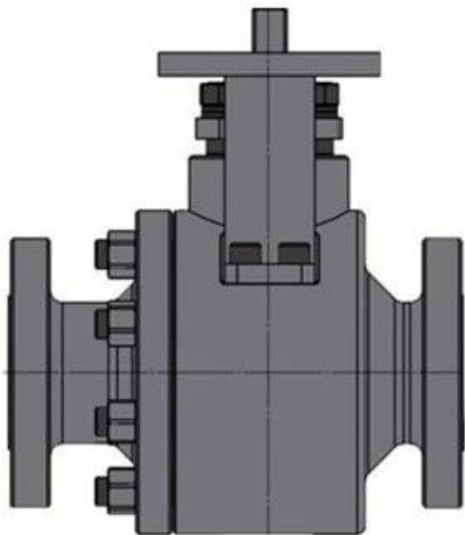

APPLICATION SCENARIO



Industrial water application



Power plant



Petroleum



Steel



Wastewater treatment



Acid-base



Healing drugs



Refined coal



Our Factory



Company Advantages



I 100% high level ex-factory inspection

II CNC precision processing

III 21 years of professional experience

IV 2 years quality assurance, repair and replacement

V GB, TUV CE, ISO 9001, ADWO-2000, TS, PED, WRC, WRAS, KTW, API 6D, API 609

