

DESIGN FEATURES

This series of butterfly valves are used for industrial pipelines, as bi-directional open and close and regulation devices, the adjustment range is from 40°C-90°C full open. Suitable temperature $\geq 80^{\circ}\text{C}$



Features

- Size range DN100-1200mm
- Standard-ISO/BS/DIN/AWWA/API
- Tests Standard-BS EN 12266-1
- Body-Ductile Iron/Cast Iron/Stainless Steel /WCB
- Body Ring-SS420/SS304/SS316
- Disc Ring-EPDM
- Shaft-SS420/SS431/SS316
- Fusion bonded epoxy coating-Min 300 Microns

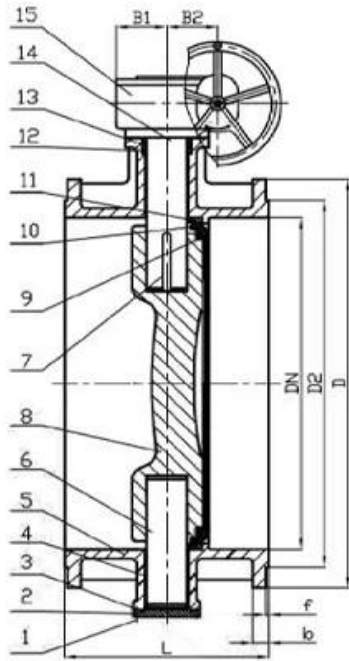
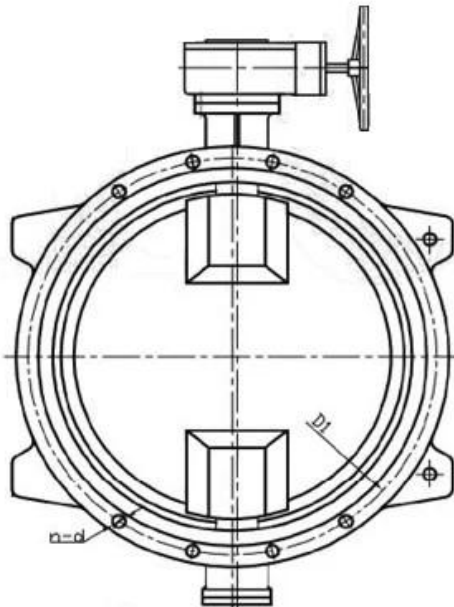

□□	DN200-DN4000
□□ □□	PN10 PN16 PN25
□□ □□ □□	□□ □□ □□
□□	SS304 / SS316
□□	□□ □□ □□
□□ □	EPDM
□□ □□ □□	□□ □□
□□ □□	BS EN1092-2:1997 PN16
□□ □□ □□	□□, HVAC, □□ □□, □□, □□ □ □ □□, □□ □□, □□ □□, □□ □□ □□ □□

APPLICATION SCENARIO



Industrial water application



Power plant



Sea water desalination



Water treatment



Water supply and drainage



HAVC



Food and drug



Water transport



COMPANY FACTORY



COMPANY INFORMATION



I 工厂: 工厂 工厂, 工厂 工厂 工厂.

II 工厂 CNC 工厂 工厂, 工厂 工厂 工厂, 工厂 工厂 工厂 工厂.

III 工厂 工厂 工厂 工厂, 工厂 工厂 工厂 工厂 工厂.

VI 工厂 工厂 工厂 工厂 工厂 工厂.

V 工厂 工厂: GB, 工厂 工厂, 工厂 工厂, TUV CE, ISO 9001, ADWO-2000, TS, PED, WRC WRAS, KTW, API 6D, API609.

VI 工厂 工厂: 工厂 工厂, 工厂 工厂, 工厂 工厂, 工厂 工厂, 工厂 工厂, 工厂 工厂, 工厂/工厂/工厂 工厂, 工厂 工厂.

01

21 years of professional experience

03

Independent research and development team
28 top senior professional researchers

05

100% high level ex-factory inspection

07

2 years quality assurance, repair and replacement

4 factories

02

2 professional testing centers

04

High quality imported materials

06

COMPANY QUALIFICATION



COMPANY EXHIBITION



Partners



Delivery



Payment



□□□□ □□:

Q: □□ □□ □□ □□ □□ □□□□?

□: □□" □□, □□, □□, □□, □□ □□□.

Q: □□ □□□□ □□ □□□□□□ □□ □ □□□□?

□: □□□, □□□, □□□, □□□□□ □□. RKSfluid □□□□□□ □□ □□□ □□□□□. □□□ □□ □□□□ □□□□□.

Q: □□ □□ □□ □□□□□?

□: RKSfluid □□□ □□□ □□ □□□ □□ □ □□ 4□□ □□□ □□□□□.

Q: □□ □□□□

□: □□ □□□ □□□ □□ 2~5□ □□□ □□□ □□□□□. □□□ □□□ □□ □□□ □□□□□□.

□□: **MOQ**

A: □□ □□□ □□ 1pc.

Q: □□ □□□ □□□□□?

A: □□ □ 100% □□ □□□, □□ 2□. □□□ □□ □□□ □□□□□□.

□□□ TUV, API, WRAS, CE, ISO □□□ □□□□□□.

□□□ DIN, ASME, BS EN, JIS, API, AWWA □□□□□□.

Q: □□□□ □□□ □□□ □□□□ □□ □ □□□?

A: RKSfluid 20□□ □□□ □□□□ □□□□ 70□ □□□ R&D □□□□□ □□ □□, □□ □□ □ □□ □□□ □□□□□.