

**RKSfluid®**



RKSfluid

**RKSfluid®**



**RKSfluid®**



**RKSfluid®**



RKSfluid

**RKSfluid®**



**RKSfluid®**



## DESIGN FEATURES

### DURABLE

- **No-pin** connection, 1 pc **blow-out proof stem**
- DI/CI Nodularity over **95%**

### ANTI-CORROSION

- Material: Epoxy powder:  , Earth Best!
- Coating Thickness: **200-250µm**
- Spraying temp: over **200°C**. Doesn't fade, even wipe with diethyl ether

### QUALITY STANDARD

- **100% quality test**, follow DIN, ASTM, JIS, GB/T, ISO, BS EN, API
- **ONLY ONE** Manufacturer get **CE** certification up to **DN1800**
- **2 years** warranty. **15000** times On-off test, **30000** times Destructive experiment



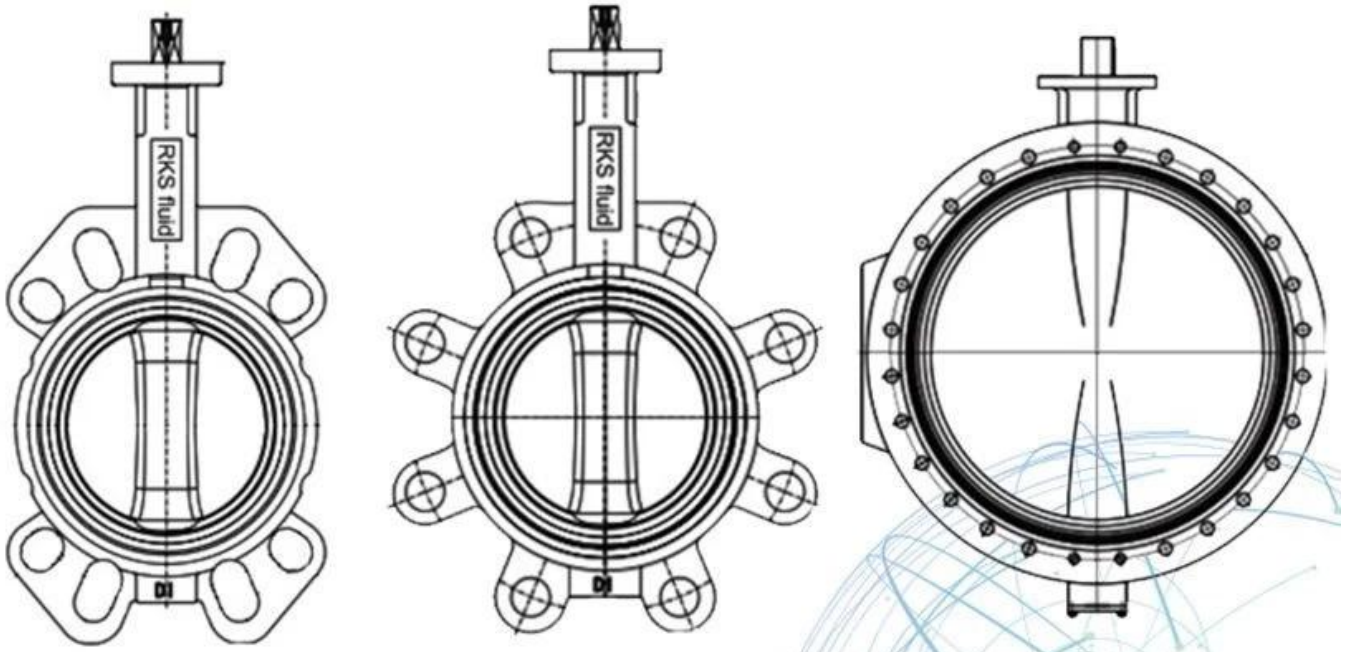

## APPLICATION SCENARIO



Industrial water application



Power plant



Sea water desalination



Water treatment



Water supply and drainage



HAVC



Food and drug



Water transport





# Our Factory



○○○○ ○○

Q : ○○○ ○○○ ○○ ○○ ○○○ ○○○○○?

A : ○○ ○○, ○○, ○○, ○○, ○○ ○○○.

Q : ○○○○○○ ○○ ○ ○ ○○○○?

A : ○○○, ○○○, ○○○, ○○○○○ ○○. RKSfluid ○○○○○○ ○○ ○○○ ○○○○○. ○○○ ○○○○○, ○○○○○ ○○○○○○○.

Q : ○○ ○○○ ○○○○○?

A : RKSfluid○○ ○○○ ○○○ ○○ ○ ○○○ 4 ○○ ○○○ ○○○○.

Q : ○○ ○○ ○○

: ○○ ○○ ○○ 2 ~ 5 ○. ○○○ ○○ ○○○ ○○.

Q : MOQ

: 1 ○ ○○ ○○.

Q : ○○○ ○○ ○○○?

: 100 % ○○ ○○○ ○○ ○○ 2 ○ ○○. ○○○ ○○ ○○○ ○○○○○○.

○○○ TUV, API, WRAS, CE, ISO ○○○ ○○○○○○.

○○○ DIN, ASME, BS EN, JIS, API, AWWA○ ○○○○○○.

Q : ○○○ ○○○○ ○○○ ○○○○ ○○ ○ ○ ○○○○?

A : RKSfluid○ 20 ○○ ○○○ ○○○○ ○○○ 70 ○ ○○○ R & D ○○○○○○ ○○ ○○, ○○ ○○ ○ ○○ ○○○ ○○○○○○.

## Exhibition Photos



## Our Certificates

