

DESIGN FEATURES

Features

1. Streamlined: minimum noise
2. Anti-static design
3. Double Block & Bleed
4. Automatic Self-Venting Seats
5. Emergency Protection

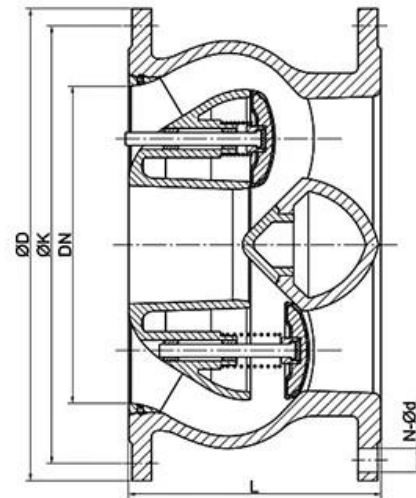

APPLICATION SCENARIO



Industrial water application



Power plant



Sea water desalination



Water treatment



Water supply and drainage



HAVC



Food and drug



Water transport



COMPANY INFORMATION



i 0000 00 : 00 00 00, 00 0 00 00 00.

CNC 00 00, 00 00 0, 0000 00 00, 00 00 00 0 00.

■ 00 00 00 000 000 0000000 000 00 00 00.

000 0000 000 00000 00 00 0000 0000000.

v 00 00 : GB, 00 00, 00 00, TUV CE, ISO 9001, ADWO-2000, TS, PED, WRC WRA, KTW, API 6D, API609.

VI 00 0000 : 00 00, 0 00, 000 00, 00 00, 000 00, 000 00, 00 / 00 / 00 00000, 00 00.

01

21 years of professional experience

03

Independent research and development team
28 top senior professional researchers

05

100% high level ex-factory inspection

07

2 years quality assurance, repair and replacement

4 factories

02

2 professional testing centers

04

High quality imported materials

06

COMPANY QUALIFICATION



COMPANY EXHIBITION



