

Silent check valves, also known as non-slam check valves and spring-assisted check valves reduce or eliminate water hammer and its effects.

- High strength ductile iron body used for durability and less weight.
- Advanced dynamic design of single body with diffuser provides streamline flow and assures lower head loss.
- One of the lowest head loss check valve, big save in pumping power cost, valve disc with shorter stroker and spring reverse faster than most of check valve.
- Coated with powder epoxy both inside & outside for corrosion resistance.
- Bronze bushing reduce wearing problem during operation.
- Hydrodynamic design with spring ensures non slamming and water hammerless.
- Stainless steel spring hidden in the diffuser under protection while valve in operation.
- Disc will positively close before reverse flow, and maximize the closing speed up to 0.2 Sec.
- Installation can be vertical/horizontal/ inclined.
- Comply with EN 558-1, ISO 5752 and EN 1092-2, ISO 7005-2 flange dimension.



- Streamlined, minimum noise
- Backflow velocity only 0.2s, Head loss 0.1bar with 2m/s
- EPDM/NBR Rubber fully coated disc
- Anti-erosion design. Self-adjusting ball
- Self-cleaning stem, Long time smooth operation

Size	DN50 - DN600 (NPS2-NPS24)
Pressure ratings	PN10/16/25
Temperature range	0°C~+80°C
Body	Ductile iron □ Stainless steel
Medium	Water, Gas
Design Standard	GB/T 12235-2007
Face to Face	EN 558-1
Flange	EN 1092-2

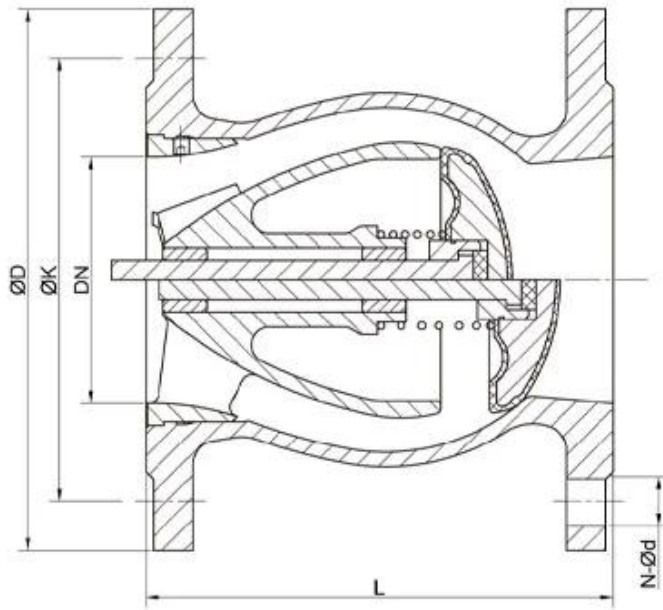

NPS2-NPS14 (DN50-DN350)

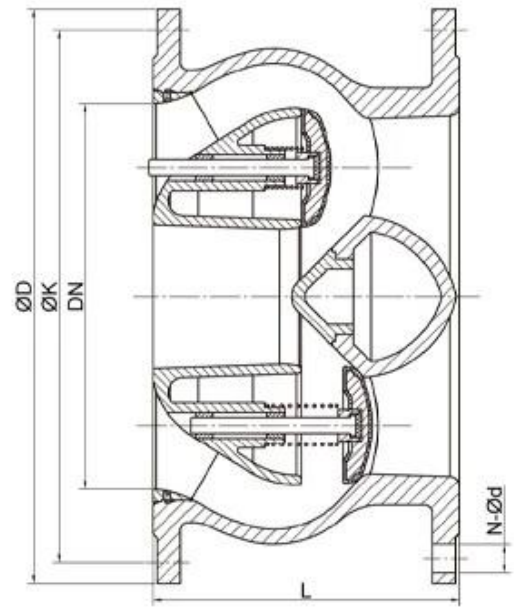

NPS16-NPS24 (DN400-DN600)



COMPANY INFORMATION



I Business area: fluid control products, technology and environmental protection products.

II Advanced CNC machining centers, professional process cells, wide-range welding equipment, automatic assembly lines and coating.

III China's standard reference unit, to participate in the development of relevant valve industry standards.

IV We have set up a research and development center in Houston, Texas, in the United States.

V Product Standard: GB, German Standard, American Standard, TUV CE, ISO 9001, ADWO-2000, TS, PED, WRC WRAS, KTW, API 6D, API609.

VI Main production: butterfly valve, ball valve, gate valve, check valve, globe valves, pipe fittings, manual / pneumatic / electric actuator, valve parts.

COMPANY FACTORY



01

21 years of professional experience

03

Independent research and development team
28 top senior professional researchers

05

100% high level ex-factory inspection

07

2 years quality assurance, repair and replacement

4 factories

02

2 professional testing centers

04

High quality imported materials

06

COMPANY QUALIFICATION



COMPANY EXHIBITION



Partners



FAQ

Q: If I need quotation, what informations do we need?

A: Valves' materials, Temperature, Pressure, Medium, Applpation System.

Q: Can you provide actuators, what you have?

A: Pneumatic, Electric, Hrdraulic, Solenoid Valves. RKSfluid actuators adopt USA technology. Which you need, just tell us.

Q: What's your productive capacity?

A: RKSfluid has four plants that can provide the products you need.

Q: Production lead time

A: Normal products have stock in 2~5 working days. Customized base on your need.

Q: MOQ

A: 1pc for all products.

Q: How about the quality assurance?

A: 100% quality test before delivery, 2 years warranty. Ensure your system working safety.

We got TUV, API, WRAS, CE, ISO certification.

Standard conform to DIN, ASME, BS EN, JIS, API, AWWA.

Q: How could you provide quality service to our customers?

A: RKSfluid own 20 years experiences and more than 70 R&D engineers provide technical support, model selection and installation guidance for you.