

**RKSfluid®**



**RKSfluid®**



RKSfluid

**RKSfluid®**



RKSfluid

**RKSfluid®**



RKSfluid

**RKSfluid®**



**RKSfluid®**



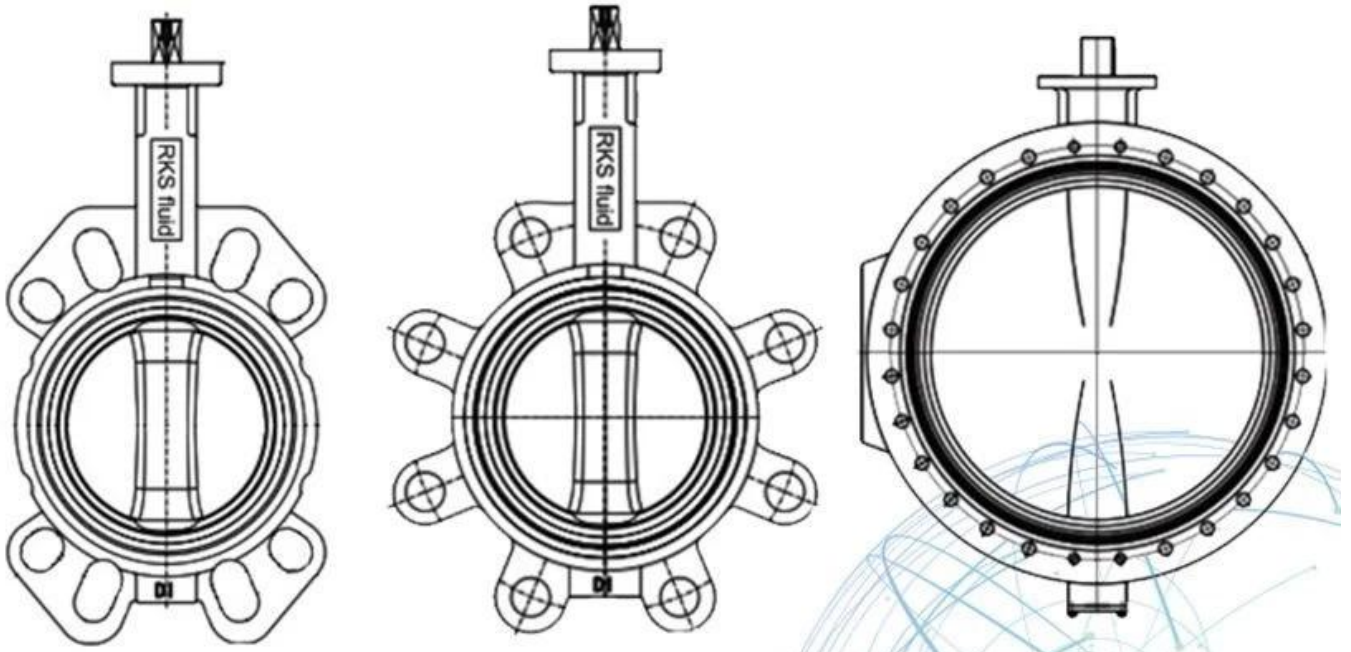

## APPLICATION SCENARIO



Industrial water application



Power plant



Sea water desalination



Water treatment



Water supply and drainage



HAVC



Food and drug



Water transport



# Our Factory



I Business area: fluid control products, technology and products for environmental protection.

II Advanced CNC machining centers, professional process cells, wide-range welding equipment, automatic assembly and coating lines.

III China's standard reference unit, to participate in the development of relevant valve industry standards.

IV We have set up a research and development center in Houston, Texas, in the United States.

V Product Standard: GB, German Standard, American Standard, TUV CE, ISO 9001, ADWO-2000, TS, PED, WRC WRAS, KTW, API 6D, API609.

VI Main Production: Butterfly Valve, Ball Valve, Gate Valve, Check Valve, Globe Valve, Pipe Fittings, Manual/Pneumatic/Electric Actuator, Valve Parts.



## Exhibition Photos



## Our Certificates

