

The Float Valve is a non-modulating valve That accurately controls the liquid level in tanks. This valve is designed to open fully when the liquid level reaches a preset low point, and close drip-tight when the level reaches a preset high point. The float pilot is remotely installed inside of reservoir.

This is a hydraulically operated, diaphragm valve with the pilot Control and float mechanism mounted on the cover of the main valve.

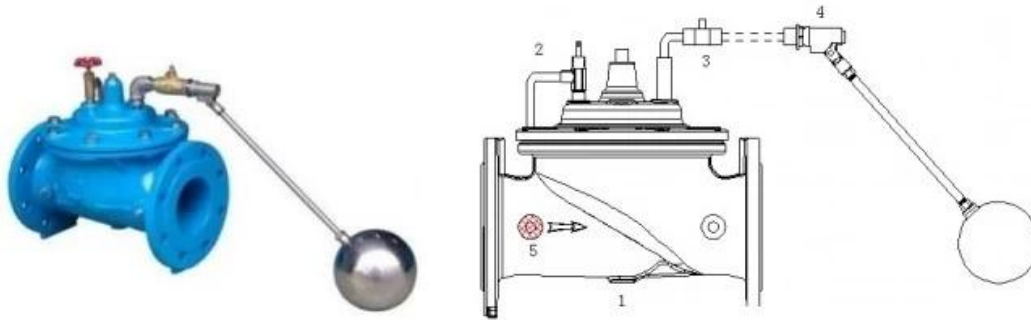

1. Main valve
5. Strainer **2. Needle valve** **3. Ball valve** **4. Float pilot**

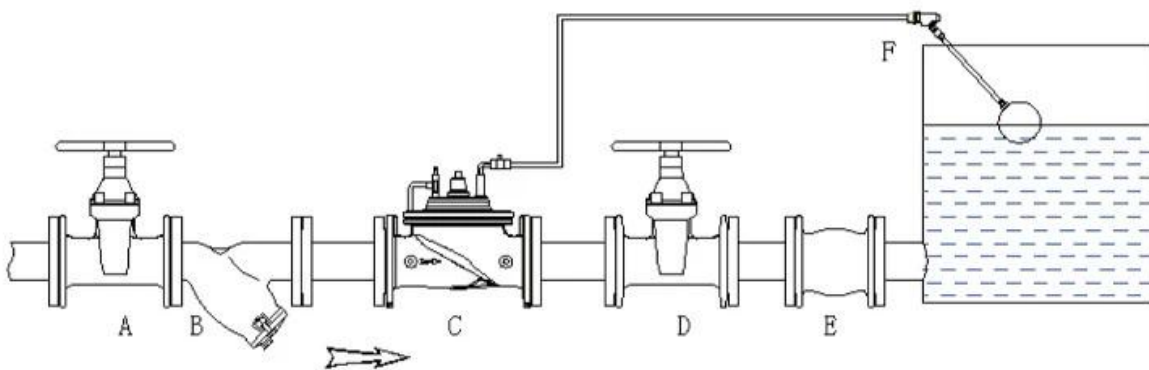

A. Shut off valve **B. Y strainer** **C. Float control valve** **D. Shut off valve** **E. Soft joint**
F. Float pilot

Standard Features

1. Single chamber and Globe type main valve;
2. Ductile Iron EN-GJS-500-7 body and bonnet;
3. CF8/SUS304 Seat and Shaft;
4. EPDM gasket and diaphragm;
5. WRAS Epoxy powder coating;
6. PN10/16/25

DN	L	H	H1	DN	L	H	H1
40	230	139	85	250	730	476	205
50	230	139	85	300	850	526	232
65	290	159	95	350	980	585	262
80	310	179	102	400	1100	624	292
100	350	214	112	500	1250	720	360
125	400	278	127	600	1450	835	424
150	480	233	145	800	1850	1110	515
200	600	407	172	1000	2250	1350	630

Highlights:

1. Fully Bore with seat diameter as DN+2 mm
2. Stable working even if the flow close to Zero
3. High performance and strength Nylon enforce diaphragm
4. One Million cycle test and 64 bar burst test
5. Fully bore (FB), Reduce bore (RB) and Anti-Cavitation Device(ACD)
6. Higher than standard product test,
 - 6.1 Seat test : $1.1 * PN + 1$ Bar
 - 6.2 Strength test : $1.5 * PN + 1$ Bar
 - 6.3 Low pressure sealing test: 0.2 Bar
7. Automatic computer test with 1000 Hz Sensor
8. Smart control valve and Solution system
9. Specialsolution for technical support



COMPANY INFORMATION



I Business area: fluid control products, technology and environmental protection products.

II Advanced CNC machining centers, professional process cells, wide-range welding equipment, automatic assembly lines and coating.

III China's standard reference unit, to participate in the development of relevant valve industry standards.

IV We have set up a research and development center in Houston, Texas, in the United States

V Product Standard: GB, German Standard, American Standard, TUV CE, ISO 9001, ADWO-2000, TS, PED, WRC WRAS, KTW, API 6D, API609.

VI Main production: butterfly valve, ball valve, gate valve, check valve, globe valves, pipe fittings, manual / pneumatic / electric actuator, valve parts

COMPANY FACTORY



01

21 years of professional experience

03

Independent research and development team
28 top senior professional researchers

05

100% high level ex-factory inspection

07

2 years quality assurance, repair and replacement

4 factories

02

2 professional testing centers

04

High quality imported materials

06

COMPANY QUALIFICATION



COMPANY EXHIBITION



Partners



Delivery



Payment



FAQ

Q: If I need quotation, what informations do we need?

A: Valves' materials, Temperature, Pressure, Medium, Appllication System.

Q: Can you provide actuators, what you have?

A: Pneumatic, Electric, Hrdraulic, Solenoid Valves. RKSfluid actuators adopt USA technology. Which you need, just tell us.

Q: What's your productive capacity?

A: RKSfluid has four plants that can provide the products you need.

Q: Production lead time

A: Normal products have stock in 2~5 working days. Customized base on your need.

Q: MOQ

A: 1pc for all products.

Q: How about the quality assurance?

A: 100% quality test before delivery, 2 years warranty. Ensure your system working safety. We got TUV, API, WRAS, CE, ISO certification. Standard conform to DIN, ASME, BS EN, JIS, API, AWWA.

Q: How could you provide quality service to our customers?

A: RKSfluid own 20 years experiences and more than 70 R&D engineers provide technical sup

port, model selection and installation guidance for you.