

**Wafer dual plate check valves**, have two springs loaded half-moon shaped discs that rotate around their shaft. They are designed to automatically prevent back-flow in systems where it is desirable to permit flow in one direction and prevent flow in the opposite direction.

I - Light weight, compact structure, easy maintenance.

II - The valve plate adopts clamp type, which can close automatically under the moment of elastic force of spring.

III - Because of the speed of closing action, can prevent the medium flow back.

IV - The valve body structure size is small, rigidity is good.

V - The valve can be safely and conveniently used for horizontal and vertical installation.

#### GENERAL APPLICATIONS

- Water Treatment
- HVAC
- Irrigation System
- Pumping
- Smart Water Control
- Power Station
- Desalination
- Food Industry
- Mining
- Petrochemical
- Coal Chemical Industry

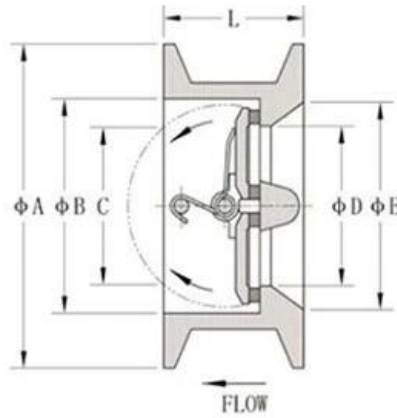

### DIMENSIONS

DN	A	B	C	D	E	L	Weight
40	92	65	49	48	59	43	0,8
50	107	65	49	48	59	43	1,3
65	127	80	63	60	78	46	1,6
80	142	94	69	70	91	64	2,8
100	162	117	97	88	110	64	4,0
125	192	145	121	115	142	70	5,5
150	218	170	145	134	170	76	8,0
200	273	224	197	182	222	89	13,5
250	328	265	234	223	264	114	24,4
300	378	310	284	260	310	114	33,0
350	438	360	333	300	360	127	46,3
400	489	410	379	355	414	140	62,0
450	539	450	415	382	450	152	100,0
500	594	505	472	435	505	152	107,0
600	695	624	579	536	605	178	158,0



# COMPANY FACTORY



## COMPANY INFORMATION



I Business area: fluid control products, technology and environmental protection products.

II Advanced CNC machining centers, professional process cells, wide-range welding equipment, automatic assembly lines and coating.

III China's standard reference unit, to participate in the development of relevant valve industry standards.

IV We have set up a research and development center in Houston, Texas, in the United States.

V Product Standard: GB, German Standard, American Standard, TUV CE, ISO 9001, ADWO-2000, TS, PED, WRC WRAS, KTW, API 6D, API609.

VI Main production: butterfly valve, ball valve, gate valve, check valve, globe valves, pipe fittings, manual / pneumatic / electric actuator, valve parts.



01

21 years of professional experience

03

Independent research and development team  
28 top senior professional researchers

05

100% high level ex-factory inspection

07

2 years quality assurance, repair and replacement

4 factories

02

2 professional testing centers

04

High quality imported materials

06

## COMPANY QUALIFICATION



## COMPANY EXHIBITION





## Partners



### Delivery



### Payment



### FAQ:

**Q: If I need quotation, what informations do we need?**

A: Valves' materials, Temperature, Pressure, Medium, Appllication System.

**Q: Can you provide actuators, what you have?**

A: Pneumatic, Electric, Hrdraulic, Solenoid Valves. RKSfluid actuators adopt USA technology. Which you need, just tell us.

**Q: What's your productive capacity?**

A: RKSfluid has four plants that can provide the products you need.

**Q: Production lead time**

A: Normal products have stock in 2~5 working days. Customized base on your need.

**Q: MOQ**

A: 1pc for all products.

**Q: How about the quality assurance?**

A: 100% quality test before delivery, 2 years warranty. Ensure your system working safety.

We got TUV, API, WRAS, CE, ISO certification.

Standard conform to DIN, ASME, BS EN, JIS, API, AWWA.

**Q: How could you provide quality service to our customers?**

A: RKSfluid own 20 years experiences and more than 70 R&D engineers provide technical support, model selection and installation guidance for you.