

Swing check valve is mounted with a disc that swings on a hinge or shaft. The disc swings off the seat to allow forward flow and when the flow is stopped, the disc swings back onto the seat to block reverse flow.

Swing check valves are available in both resilient and metal sealing. It's normally recommended for water and wastewater systems applications because of the simple construction, low pressure drop across the valve, and field service ability.

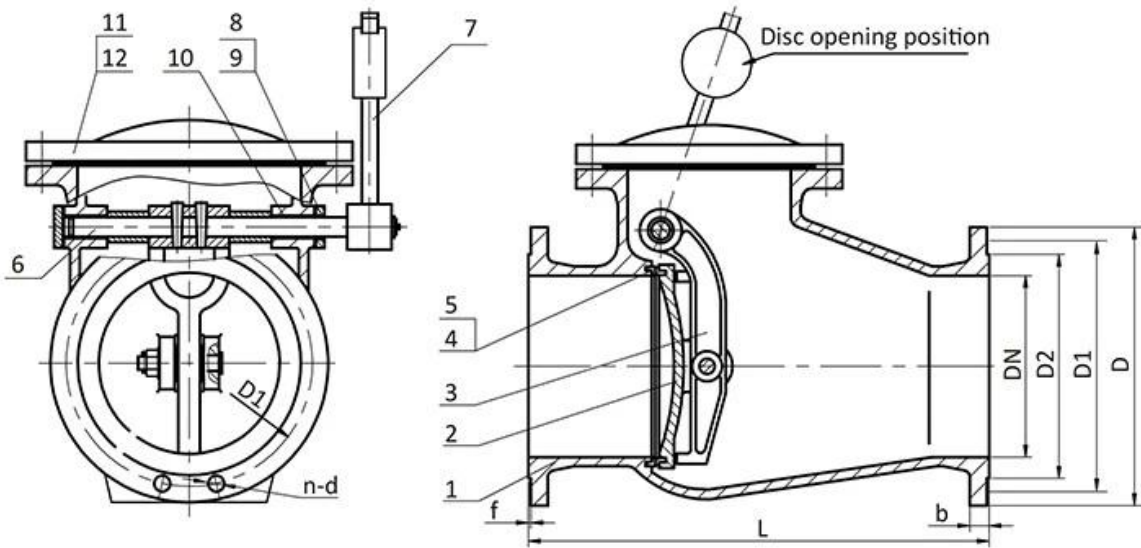

Design	BS EN 12334
Flange	BS EN1092-2:1997 PN10
Face to Face	DIN3202 F6
Tests	BS EN 12266-1:2003 Rate B
Operation	Self-motion
Medium	Oil, Water, Gas, Sewage, etc.
Temperature	≤80°C
PN	PN10, PN16
DN	DN50-DN1600



APPLICATION SCENARIO



Industrial water application



Power plant



Sea water desalination



Water treatment



Water supply and drainage



HAVC



Food and drug



Water transport



COMPANY INFORMATION



- I Business area: fluid control products, technology and environmental protection products.
- II Advanced CNC machining centers, professional process cells, wide-range welding equipment, automatic assembly lines and coating.
- III China's standard reference unit, to participate in the development of relevant valve industry standards.
- IV We have set up a research and development center in Houston, Texas, in the United States.
- V Product Standard: GB, German Standard, American Standard, TUV CE, ISO 9001, ADWO-2000, TS, PED, WRC WRAS, KTW, API 6D, API609.
- VI Main production: butterfly valve, ball valve, gate valve, check valve, globe valves, pipe fittings, manual / pneumatic / electric actuator, valve parts.



COMPANY EXHIBITION



COMPANY QUALIFICATION



Partners



Delivery



Payment



FAQ:

Q: If I need quotation, what informations do we need?

A: Valves' materials, Temperature, Pressure, Medium, Applplication System.

Q: Can you provide actuators, what you have?

A: Pneumatic, Electric, Hrdraulic, Solenoid Valves. RKSfluid actuators adopt USA technology. Which you need, just tell us.

Q: What's your productive capacity?

A: RKSfluid has four plants that can provide the products you need.

Q: Production lead time

A: Normal products have stock in 2~5 working days. Customized base on your need.

Q: MOQ

A: 1pc for all products.

Q: How about the quality assurance?

A: 100% quality test before delivery, 2 years warranty. Ensure your system working safety.

We got TUV, API, WRAS, CE, ISO certification.

Standard conform to DIN, ASME, BS EN, JIS, API, AWWA.

Q: How could you provide quality service to our customers?

A: RKSfluid own 20 years experiences and more than 70 R&D engineers provide technical support, model selection and installation guidance for you.