



RKSfluid®

A key Valve in Flow Control



Butterfly Valve



Ball Valve



Gate Valve



Globe Valve



Check Valve



Pipe Fittings

GRIFFFIN series PTFE lined butterfly valve

Design Features



Stem to Disc Connections

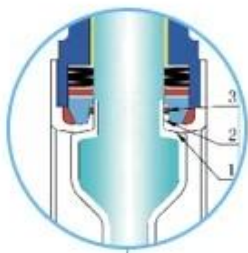

1. Primary Seal: Spring loaded Mechanical seal
2. Secondary Seal: Radial Lip Seal
3. Third Seal: FPM



Safety slot for over torque protection

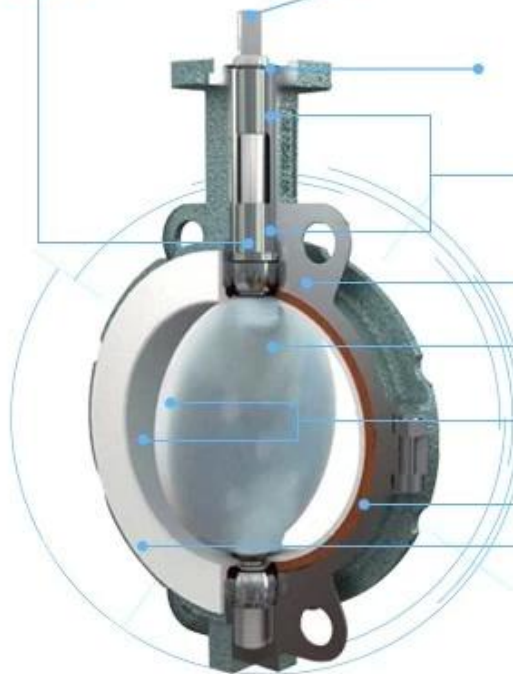

- Top flange meets ISO5211 standard
- Bushing
- WCB / CF8M Bodies
- One piece (non welded) PFA molded ASTM A890 Duplex disc stem.
- Radial lip seal between body and disc for better seal performance
- Elastomer Back-up Silicon or FPM
- Isostatic molded PTFE Seat for consistent density throughout the seat areas

Seat Liner
Material: PTFE



One Piece Disc Stem PFA Lined

Material:
1.4462/1.4469 + PFA (Standard)
17-4PH + PFA
CF8/CF8M/CF3/CF3M + PFA



Elastomer Back-up
Material:
Viton/silicone



Parts: Body
Material:
WCB (Standard)
CF8M, CF8 (Optional)



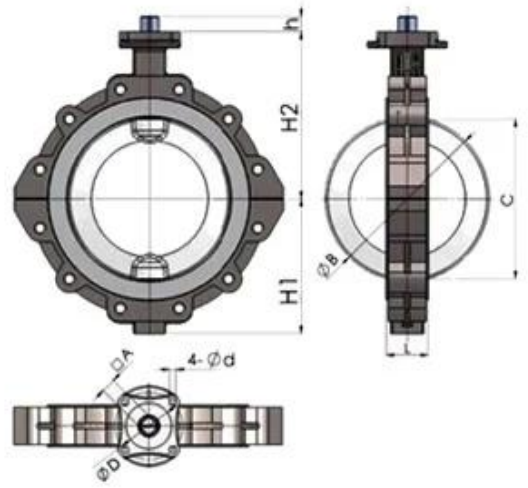
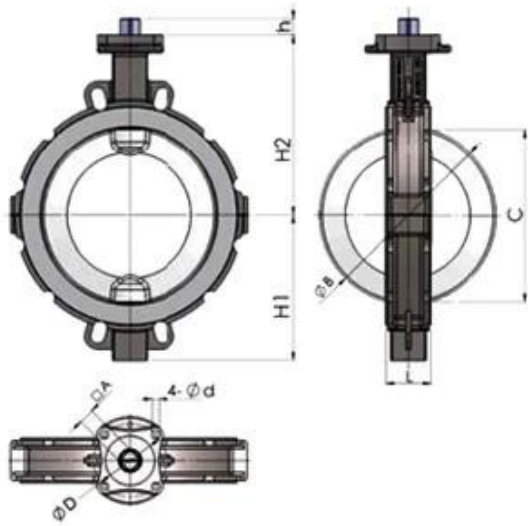

Our Factory



Company Advantages

01

21 years of professional experience

03

Independent research and development team
28 top senior professional researchers

05

100% high level ex-factory inspection

07

2 years quality assurance, repair and replacement

4 factories

02

2 professional testing centers

04

High quality imported materials

06



RKSfluid was founded in 1997. We are a production workshop both for foundry and for processing, research and & development center and quality control center. Production the facilities include numerical control work centers, professional processing cells, broad spectrum welding equipment, automatic assembly and coating lines. We have created a design team, research and & development. Our new testing center as a testing center for public service platforms a Liaoning Province, Become the standard GB of the Chinese valve reference unit, to participate in developing the relevant valves industry standards. In order to speed up the overseas business expansion and resource integration, and to support the success of RKS fluid sales in the United States, Germany and Russia. We have an American agent. Our product design standards Coverage: GB, ISO, German and American standard, approved by TUV for CE and ADWO-2000, ISO9001, TS, API. Our products: manual, pneumatic and & electrically controlled ball valves Butterfly valves and gate valves. Check valves, automatic control valves. Castings and Fittings: valve bodies, hoods, disks, stems, gearbox, universal joints, flange adapters, Tapping Saddle: after years of development, we continue to improve and seek innovation while adhering to "proven technology, superior features and legendary value" like ours product value philosophy. Customer satisfaction is our business goal! RKSfluid was founded in 1997.

We are a production laboratory both for foundry and processing, research and & development center and quality control center. Production the facilities include numerical control work centers, professional processing cells, broad spectrum welding equipment, automatic assembly and coating lines. We have created a design team, research and & development. Our new testing center as a testing center for public service platforms a Liaoning Province, Become the standard GB of the Chinese valve reference unit, to participate in developing the relevant valves industry standards. In order to speed up the

overseas business expansion and resource integration, and to support the success of RKS fluid sales in the United States, Germany and Russia. We have an American agent. Our product design standards

Coverage: GB, ISO, German and American standard, approved by TUV for CE and ADWO-2000,

ISO9001, TS, API. Our products: manual, pneumatic and & electrically controlled ball valves Butterfly valves and gate valves. Check valves, automatic control valves. Castings and Fittings: valve bodies, hoods, discs, stems, gearbox, universal joints, flange adapters, Tapping Saddle: after years of development, we continue to improve and seek innovation while adhering to "proven technology, superior features and legendary value" like ours product value philosophy. Customer satisfaction is our business goal!

Business Business area: products for fluid control, technology and products for environmental protection.

II Advanced numerical control work centers, professional process cells, welding equipment, automatic assembly lines and coating.

III Standard reference unit of China, to participate in the development of relevant standards in the valve industry.

IV We have set up a research and development center in Houston, Texas, in the United States.

Prodotto Product standards: GB, German standard, American standard, TUV CE, ISO 9001, ADWO-2000, TS, PED, WRC WRAS, KTW, API 6D, API609.

VI Main production: butterfly valve, ball valve, gate valve, non-return valve, globe valves, pipe fittings, manual / pneumatic / electric actuator, valve parts.

Exhibition Photos



Our Certificates



FAQ

Q: If I need a quote, what information do we need?

A: valve materials, temperature, pressure, medium, application system.

Q: Can you supply actuators, what do you have?

A: Pneumatic, electric, hydraulic solenoid valves. RKSfluid actuators adopt US technology. As you need, just tell us.

Q: What is your production capacity?

A: RKSfluid has four plants able to supply the products you need.

Q: production lead time

A: Normal products are available in 2 ~ 5 working days. Base customized for your needs.

Q: MOQ

A: 1 pc for all products.

Q: How about quality assurance?

A: 100% quality test before delivery, 2 years warranty. Ensure the safe operation of the system.

We have obtained the TUV, API, WRAS, CE, ISO certification.

Standard compliant with DIN, ASME, BS EN, JIS, API, AWWA.

Q: How can we provide a quality service to our customers?

A: RKSfluid has 20 years of experience and over 70 research and development engineers provide technical support, model selection and installation guide.

PTFE Rubber Wafer Type Ductile Iron Material Pneumatic Butterfly Valve