



- Fireproof structural design, API607 / API6FA Standard
- Flexible sealing ring structure, reliable seating
- Safety locking device, error prevention
- Double block & bleed
- Anti-static design

TYPHON series Metal Seal Ball Valve

Design Features



- The whole configuration -

TYPHON series valve is a floating uni-directional seated ball valve. It includes the main body, secondary body, the main seat, secondary seat, belleville spring, ball, universal joint, stem, packing gland, packing. The body, seat and ball are forged. The maximum temperature endurance is 800 °C. It is used for three-phase flow (gas, solid, liquid), high erosion, high hard granular media, easy to coke materials and high frequency switching conditions.

- Full metal Hard seal -

Between the ball and the seat is metal spherical seal. Between the main seat and the body is the metal flat seal. There is no non-metallic gasket between the seals. The seal pair has tested to "zero leakage".

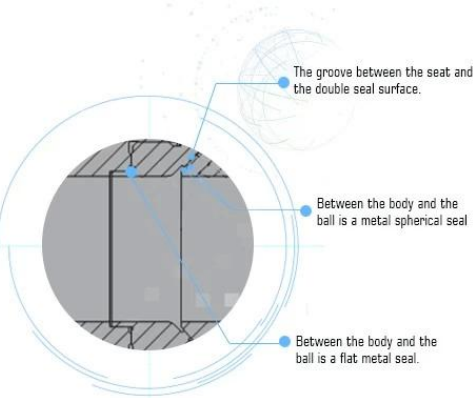

The groove between the seat and the double seal surface.

Between the body and the ball is a metal spherical seal

Between the body and the ball is a flat metal seal.

- Double-arc incision design -

The ball inlet and outlet are designed for double-arc incision, and the two incisions are rotated 180 degrees symmetrically. This design can instantaneously expand the flow area when open and close, reducing the media flow rate, thereby reducing the erosion damage of the ball and the valve seat sealing surface, extending the service life of the valve.

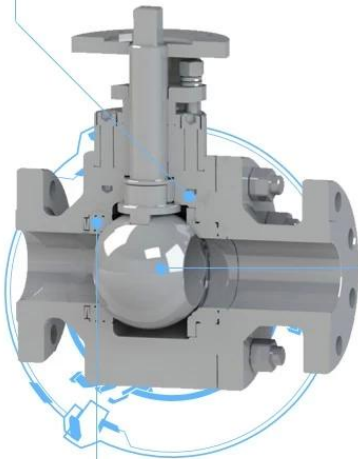

- Spring box design -

The side seat is installed in the seat pocket of the main body. The belleville spring is installed in the spring box formed by the body and the seat. The inner and outer sides of the secondary seat are provided with labyrinth grooves, which prevent the media particles from entering the spring chamber and affecting the spring action.

The secondary seat is driven by a spring to move along the passage axis while providing the preload between the main seat, the secondary seat and the ball.

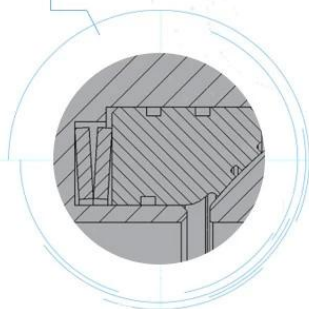

Engineering Projects



Partners



PTFE lined butterfly valve



Resilient seat butterfly valve



Double offset butterfly valve



Triple offset butterfly valve



Ball valve

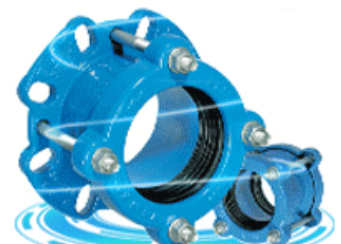

Pipe fittings

Our Factory



Company Advantages

01

21 years of professional experience

03

Independent research and development team
28 top senior professional researchers

05

100% high level ex-factory inspection

07

2 years quality assurance, repair and replacement

4 factories

02

2 professional testing centers

04

High quality imported materials

06



I Business area: fluid control products, technology and environmental protection products.

II Advanced CNC machining centers, professional process cells, welding equipment, automatic assembly lines and coating.

III China's standard reference unit, to participate in the development of relevant valve industry standards.

IV We have set up a research and development center in Houston, Texas, in the United States.

V Product Standard: GB, German Standard, American Standard, TUV CE, ISO 9001, ADWO-2000, TS, PED, WRC WRAS, KTW, API 6D, API609.

VI Main production: butterfly valve, ball valve, gate valve, check valve, globe valves, pipe fittings, manual / pneumatic / electric actuator, valve parts.

Exhibition Photos



Our Certificates



FAQ

Q: If I need quotation, what informations do we need?

A: Valves' materials, Temperature, Pressure, Medium, Application System.

Q: Can you provide actuators, what you have?

A: Pneumatic, Electric, Hydraulic, Solenoid Valves. RKSfluid actuators adopt USA technology. Which you need, just tell us.

Q: What's your productive capacity?

A: RKSfluid has four plants that can provide the products you need.

Q: Production lead time

A: Normal products have stock in 2~5 working days. Customized base on your need.

Q: MOQ

A: 1pc for all products.

Q: How about the quality assurance?

A: 100% quality test before delivery, 2 years warranty. Ensure your system working safety.

We got TUV, API, WRAS, CE, ISO certification.

Standard conform to DIN, ASME, BS EN, JIS, API, AWWA.

Q: How could you provide quality service to our customers?

A: RKSfluid own 20 years experiences and more than 70 R&D engineers provide technical support, model selection and installation guidance for you.