

Product Overview

Mass air release
Micro air release
Anti-hammer
Air breath into and protect pipeline
Two pcs PP float

Standard Features

Body: EN-GJS500-7 with Epoxy coating, float is PE/PP, rubber parts is NBR, stainless steel parts are SUS304



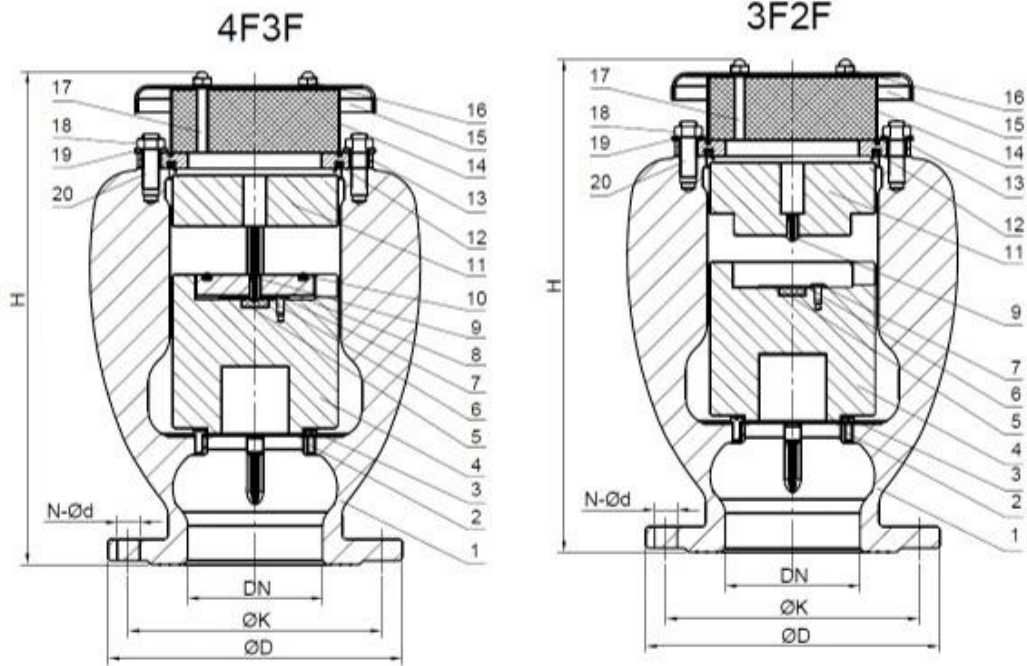

300	445	460	485	515	φ 400	φ 410	φ 430	φ 450	12- φ 23	12- φ 28	16- φ 31	16- φ 34	980	286	800	205
250	395	405	425	450	φ 350	φ 355	φ 370	φ 385	12- φ 23	12- φ 28	12- φ 31	12- φ 34	800	185	650	139
200	340	360	375		φ 295		φ 310	φ 320	8- φ 23	12- φ 23	12- φ 28	12- φ 31	650	129	520	76
150	285		300		φ 240			φ 250		φ 8-23		8- φ 28	520	70	370	39
100	220		235		φ 180			φ 190		φ 8-19		8- φ 23	370	34	300	28
80	200				φ 160				φ 8-19				300	26	220	15.5
50	165				φ 125				φ 4-19				220	14.5	-	-
DN	PN10	PN16	PN25	PN40	PN10	PN16	PN25	PN40	PN10	PN16	PN25	PN40	H(mm)	Weight (kg)	H(mm)	Weight (kg)
	φ D (mm)				φ K (mm)				N-φd (mm)				Full Bore		Reduced Bore	

COMPANY INFORMATION



RKSfluid was founded in 1997. We are a production workshop for both foundry and machining, research & development center, and quality inspection center. The manufacturing facilities include CNC machining centers, professional processing cells, broad spectrum welding equipment, automatic assembling and coating lines. We have built a team for design, research & development. Our new testing center as a public service platform testing center in Liaoning Province, Become the standard GB of the Chinese valve reference unit, to participate in the development of the relevant valve industry standards. In order to accelerate the expansion of overseas business and resources integration, and to support the success of RKSfluid sales in the USA, German, Russia. We have US Agent.

Our product design standards cover: GB, ISO, German and American Standard, approved by TUV for CE and ADWO- 2000, ISO9001, TS, API.

Our products: Manual, Pneumatically & electrically operated Ball valves, Butterfly valves and Gate Valves. Check Valves, Automatic Control Valves.

Castings and Fittings: Valve bodies, Bonnets, Discs, Stems, Gear Box, Universal Couplings, Flange Adaptors, Tapping Saddles.

After years of development, we continue to improve and seek out innovation while adhering to "Proven Technology, Superior Features and Legendary Value" as our product value philosophy.

Customer satisfaction is our working goal!

COMPANY FACTORY



I Business area: fluid control products, technology and environmental protection products.

II Advanced CNC machining centers, professional process cells, welding equipment, automatic assembly lines and coating.

III China's standard reference unit, to participate in the development of relevant valve industry standards.

IV We have set up a research and development center in Houston, Texas, in the United States.

V Product Standard: GB, German Standard, American Standard, TUV CE, ISO 9001, ADWO-2000, TS, PED, WRC WRAS, KTW, API 6D, API609.

VI Main production: butterfly valve, ball valve, gate valve, check valve, globe valves, pipe fittings, manual / pneumatic / electric actuator, valve parts.



COMPANY QUALIFICATION



COMPANY EXHIBITION



Partners



Delivery



Payment



FAQ:

Q: If I need quotation, what informations do we need?

A: Valves' materials, Temperature, Pressure, Medium, Appllication System.

Q: Can you provide actuators, what you have?

A: Pneumatic, Electric, Hrdraulic, Solenoid Valves. RKSfluid actuators adopt USA technology. Which you

need, just tell us.

Q: What's your productive capacity?

A: RKSfluid has four plants that can provide the products you need.

Q: Production lead time

A: Normal products have stock in 2~5 working days. Customized base on your need.

Q: MOQ

A: 1pc for all products.

Q: How about the quality assurance?

A: 100% quality test before delivery, 2 years warranty. Ensure your system working safety.

We got TUV, API, WRAS, CE, ISO certification.

Standard conform to DIN, ASME, BS EN, JIS, API, AWWA.

Q: How could you provide quality service to our customers?

A: RKSfluid own 20 years experiences and more than 70 R&D engineers provide technical support, model selection and installation guidance for you.