

RKSfluid®



RKSfluid®



RKSfluid®



DESIGN FEATURES

DURABLE

- No-pin connection, 1 pc blow-out proof stem
- DI/CI Nodularity over 95%

ANTI-CORROSION

- Material: Epoxy powder:  , Earth Best!
- Coating Thickness: 200-250µm
- Spraying temp: over 200°C. Doesn't fade, even wipe with diethyl ether

QUALITY STANDARD

- 100% quality test, follow DIN, ASTM, JIS, GB/T, ISO, BS EN, API
- ONLY ONE Manufacturer get CE certification up to DN1800
- 2 years warranty. 15000 times On-off test, 30000 times Destructive experiment



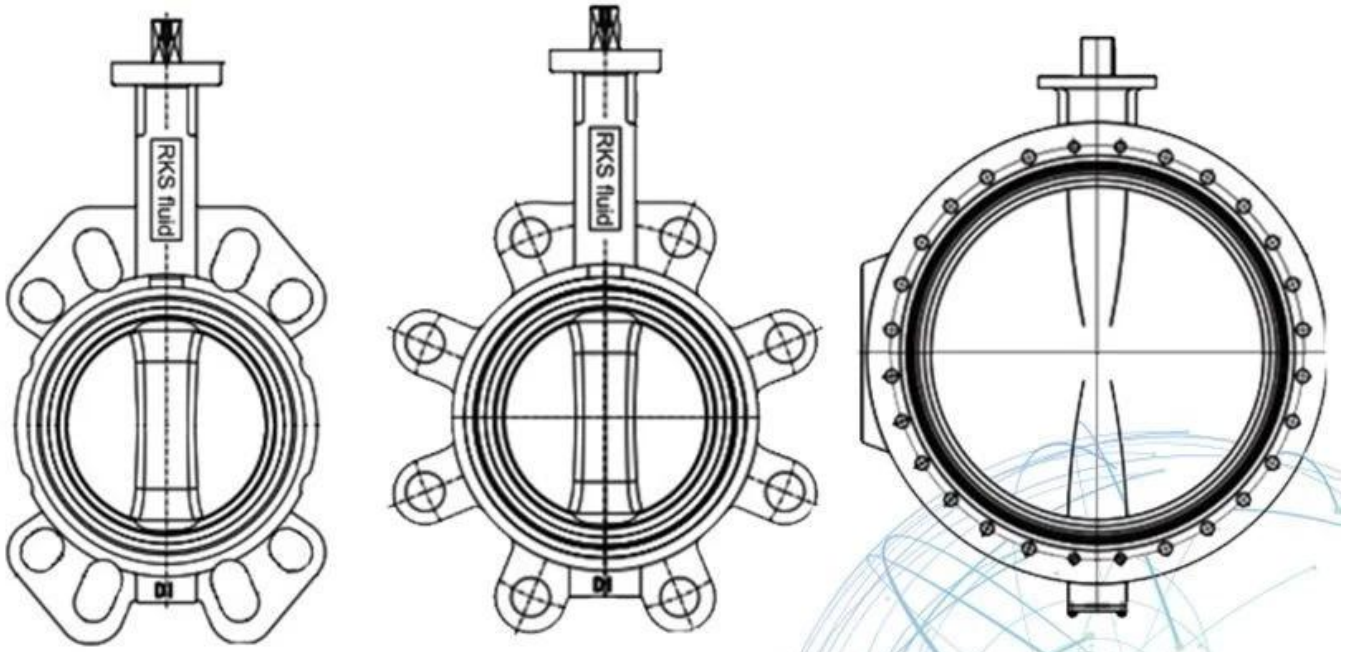

APPLICATION SCENARIO



Industrial water application



Power plant



Sea water desalination



Water treatment



Water supply and drainage



HAVC



Food and drug



Water transport



RKSfluid was founded in 1997. We are a production workshop both for foundry and for processing, research and & development center and quality control center. Production the facilities include numerical control work centers, professional processing cells, broad spectrum

welding equipment, automatic assembly and coating lines. We have created a design team, research and & development. Our new testing center as a testing center for public service platforms a

Liaoning Province, Become the standard GB of the Chinese valve reference unit, to participate

in developing the relevant valves industry standards. In order to speed up the overseas business expansion and resource integration, and to support the success of RKS fluid sales in the United States, Germany and Russia. We have an American agent. Our product design standards

Coverage: GB, ISO, German and American standard, approved by TUV for CE and ADWO-2000,

ISO9001, TS, API. Our products: manual, pneumatic and & electrically controlled ball valves Butterfly valves and gate valves. Check valves, automatic control valves. Castings and Fittings: valve bodies, hoods, disks, stems, gearbox, universal joints, flange adapters, Tapping Saddle: after years of development, we continue to improve and seek innovation while adhering to "proven technology, superior features and legendary value" like ours product value philosophy. Customer satisfaction is our business goal! RKSfluid was founded in 1997.

We are a production laboratory both for foundry and processing, research and & development center and quality control center. Production the facilities include numerical control work centers, professional processing cells, broad spectrum

welding equipment, automatic assembly and coating lines. We have created a design team, research and & development. Our new testing center as a testing center for public service platforms a

Liaoning Province, Become the standard GB of the Chinese valve reference unit, to participate

in developing the relevant valves industry standards. In order to speed up the overseas business expansion and resource integration, and to support the success of RKS fluid sales in the United States, Germany and Russia. We have an American agent. Our product design standards

Coverage: GB, ISO, German and American standard, approved by TUV for CE and ADWO-2000,

ISO9001, TS, API. Our products: manual, pneumatic and & electrically controlled ball valves Butterfly valves and gate valves. Check valves, automatic control valves. Castings and Fittings: valve bodies, hoods, discs, stems, gearbox, universal joints, flange adapters, Tapping Saddle: after years of development, we continue to improve and seek innovation while adhering to "proven technology, superior features and legendary value" like ours product value philosophy. Customer satisfaction is our business goal!

Business Business area: products for fluid control, technology and products for environmental protection.

II Advanced numerical control work centers, professional process cells, welding equipment, automatic assembly lines and coating.

III Standard reference unit of China, to participate in the development of relevant standards in the valve industry.

IV We have set up a research and development center in Houston, Texas, in the United States.

Prodotta Product standards: GB, German standard, American standard, TUV CE, ISO 9001, ADWO-2000, TS, PED, WRC WRAS, KTW, API 6D, API609.

VI Main production: butterfly valve, ball valve, gate valve, non-return valve, globe valves, pipe fittings, manual / pneumatic / electric actuator, valve parts.

Our Factory





PTFE Butterfly Valve



PTFE Butterfly Valve



PTFE Butterfly Valve

BSEN 1092, DIN 2501, ANSI, JIS, AS2129

Size: DN50~DN600

Body: Ductile Iron

Disc: Ductile Iron+PTFE

Seat: PTFE

Connection: Wafer, Lug, Flange

BSEN 1092, DIN 2501, ANSI, JIS, AS2129

Size: DN50~DN600

Body: Ductile Iron

Disc: Ductile Iron+PTFE

Seat: PTFE

Connection: Wafer, Lug, Flange

BSEN 1092, DIN 2501, ANSI, JIS, AS2129

Size: DN50~DN600

Body: WCB, CF8, CF8M

Disc: CF8+PTFE, CF8M+PTFE

Seat: PTFE

Connection: Wafer, Lug



PTFE Butterfly Valve



PTFE Butterfly Valve



PTFE Butterfly Valve

BSEN 1092, DIN 2501, ANSI, JIS, AS2129

Size: DN50~DN600

Body: WCB, CF8, CF8M

Disc: CF8+PTFE, CF8M+PTFE

Seat: PTFE

Connection: Wafer, Lug

BSEN 1092, DIN 2501, ANSI, JIS, AS2129

Size: DN50~DN600

Body: Ductile Iron

Disc: CF8, CF8M

Seat: PTFE

Connection: Wafer, Lug, Flange

BSEN 1092, DIN 2501, ANSI, JIS, AS2129

Size: DN50~DN600

Body: WCB

Disc: CF8 +PTFE, CF8 +PFA

Seat: PTFE

Connection: Wafer, Lug, Flange



Resilient seat butterfly valve



Resilient seat butterfly valve



Resilient seat butterfly valve

PN10/PN16, ANSI 125LB/150LB,5K/10K

Size:DN25-DN2400

Body:DI CI

Disc: Stainless steel

Seat :EPDM, NBR, Viton

Connection: Wafer, Lug, Flange

PN10/PN16, ANSI 125LB/150LB,5K/10K

Size:DN25-DN2400

Body:DI CI

Disc: DI+ Nylon

Seat :EPDM, NBR, Viton

Connection: Wafer, Lug, Flange

PN10/PN16, ANSI 125LB/150LB,5K/10K

Size:DN25-DN2400

Body:DI CI

Disc: Stainless steel

Seat :EPDM, NBR, Viton

Connection: Wafer, Lug, Flange



Resilient seat butterfly valve



Double flange resilient seat butterfly valve



Short-neck butterfly valve for petroleum

PN10/PN16, ANSI 125LB/150LB,5K/10K

Size:DN25-DN2400

Body:DI CI

Disc: Stainless steel

Seat :EPDM, NBR, Viton

Connection: Wafer, Lug, Flange

PN10/PN16, ANSI 125LB/150LB, 5K/10K

Size:DN50-DN1000

Body:DI CI

Disc: Stainless steel

Seat :EPDM, NBR, Viton

Connection: Flange

ANSI 125LB/150LB

Top Flange Standard:ISO5211

Size:2"-12"

Body: DI CI

Disc :Stainless Steel

Seat : EPDM, NBR, Viton

Connection:Wafer, Lug

Our Certificates

