

DESIGN FEATURES



Features



- Use AkzoNobel material.
- Super Anti-corrosion
- Epoxy powder coating 200-250um,
- Baking varnish over 200°C,

NO.		
1	Body	GGG50
2	Dise	GGG40+EPDM
3	Wedge nut	C48600
4	Stem	SS431
5	Bonnet	GT450-10
6	Gasket	EPDM
7	Y-ring	EPDM85-90
8	Fix ring	CuZn21Si3/C69300
9	Thrust bearing	C69300
10	Seal ring	EPDM70
11	O ring	NBR
12	Retainer ring	POM
13	Bushing ring	POM
14	Gland	SS431
15	Dustproof ring	EPDM85
16	Dise core	GGG40
17	Bolt	SS316

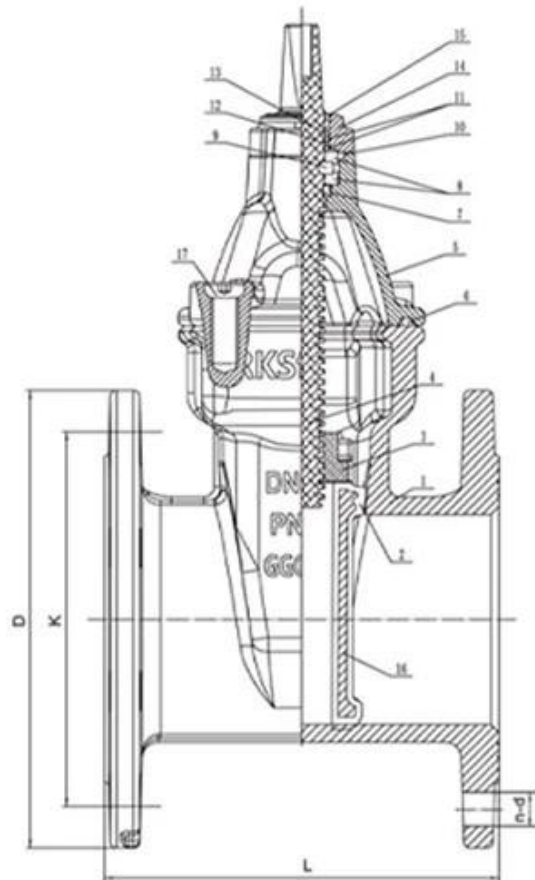



Free wedge nut, **reduces the stem bending forces** and at the same time enables it to be easily replaced.



The more compact new cap, **reduces the water retention areas** in order to reduce the risk of bacterial growth.



One piece stainless steel stem in for **better resistance to axial load** and to with stand higher operating torques.



Three locking tab for bayonet system prevents self-dismantling.



Dust guard integrating three O-ring shape, **prohibiting the introduction of foreign bodies** at the stem.



Male guiding system with composite sliding skate reduces the wear of the wedge against the body, allowing a smooth functionality and a longer life time of the valve.



Triple seal at the operating stem to ensure tightness with the test of time (2500 cycles).



New male composite sliding skate technology ensuring a low operating torque even under high differential pressure and preventing damage or corrosion generated by the friction.

RELATED PRODUCTS



APPLICATION SCENARIO



Industrial water application



Power plant



Sea water desalination



Water treatment



Water supply and drainage



HAVC



Food and drug



Water transport



COMPANY INFORMATION



I Área de negócios: produtos de controle de fluidos, tecnologia e produtos de proteção ambiental.

II Centros avançados de usinagem CNC, células de processo profissional, equipamentos de soldagem de ampla gama, linhas de montagem automática e revestimento.

III A unidade de referência padrão da China, para participar do desenvolvimento de padrões relevantes do setor de válvulas.

IV Criamos um Centro de Pesquisa e Desenvolvimento em Houston, Texas, nos Estados Unidos.

V Norma do produto: GB, Padrão Alemão, American Standard, TUV CE, ISO 9001, ADWO-2000, TS, PED, WRC WRAS, KTW, API 6D, API609.

VI Produção principal: válvula de borboleta, válvula de esfera, válvula de porta, válvula de retenção, válvulas globos, acessórios de tubo, atuador manual / pneumático / elétrico, peças de válvula.

COMPANY FACTORY



COMPANY QUALIFICATION



COMPANY EXHIBITION



Perguntas frequentes

P: Se eu precisar de cotação, que informações precisamos?

A: Materiais das válvulas, temperatura, pressão, médio, sistema de application.

P: Você pode fornecer atuadores, o que você tem?

A: válvulas pneumáticas, elétricas, hidráulicas e solenóides. Os atuadores RKSfluid adotam a tecnologia dos EUA. Que você precisa, basta nos dizer.

P: Qual é a sua capacidade produtiva?

R: RKSfluid possui quatro plantas que podem fornecer os produtos necessários.

Q: Time de lead de produção

R: Os produtos normais têm estoque em 2 ~ 5 dias úteis. Base personalizada sobre sua necessidade.

Q: MOQ

A: 1PC para todos os produtos.

P: E a garantia da qualidade?

R: Teste de 100% de qualidade antes da entrega, 2 anos de garantia. Certifique-se de sua segurança de trabalho do sistema.

Tivemos a certificação ISO TUV, API, WRAS, CE, ISO.

Standard em conforma a Din, ASME, BS EN, JIS, API, AWWA.

P: Como você poderia fornecer serviço de qualidade aos nossos clientes?

R: RKSfluid possuem 20 anos de experiência e mais de 70 engenheiros de P&D fornecem suporte técnico, seleção de modelos e orientação de instalação para você.