

Wafer

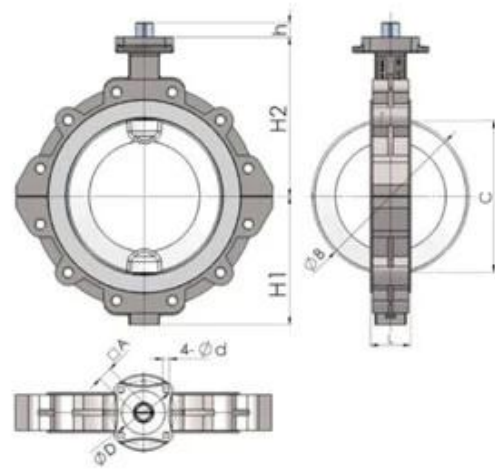

Lug

IMPERIAL DIMENSIONS:Inches

Size	L	H1	H2	h	A	B	C	D	d	ISO5211
NPS2	1.69	2.20	5.31	0.47	0.43	2.01	1.08	1.97	0.28	F05
NPS2 1/2	1.81	3.35	5.91	0.47	0.43	2.72	1.99	1.97	0.28	F05
NPS3	1.81	3.74	6.30	0.63	0.55	3.27	2.70	2.76	0.35	F07
NPS4	2.05	4.13	7.09	0.63	0.55	4.06	3.50	2.76	0.35	F07
NPS5	2.20	4.92	7.68	0.63	0.55	5.00	4.49	2.76	0.35	F07
NPS6	2.20	5.71	10.04	0.63	0.55	5.98	5.57	2.76	0.35	F07
NPS8	2.36	6.69	9.45	0.83	0.75	7.99	7.64	4.02	0.47	F10
NPS10	2.68	8.07	11.81	0.94	0.87	10.00	9.65	4.92	0.51	F12
NPS12	3.07	9.84	12.20	1.14	1.06	12.01	11.61	4.92	0.51	F12



PTFE Butterfly Valve

BSEN 1092, DIN 2501, ANSI, JIS, AS2129

Size: DN50~DN600

Body: Ductile Iron

Disc: Ductile Iron+PTFE

Seat: PTFE

Connection: Wafer, Lug, Flange



PTFE Butterfly Valve

BSEN 1092, DIN 2501, ANSI, JIS, AS2129

Size: DN50~DN600

Body: Ductile Iron

Disc: Ductile Iron+PTFE

Seat: PTFE

Connection: Wafer, Lug, Flange



PTFE Butterfly Valve

BSEN 1092, DIN 2501, ANSI, JIS, AS2129

Size: DN50~DN600

Body: WCB, CF8, CF8M

Disc: CF8+PTFE, CF8M+PTFE

Seat: PTFE

Connection: Wafer, Lug



PTFE Butterfly Valve

BSEN 1092, DIN 2501, ANSI, JIS, AS2129

Size: DN50~DN600

Body: WCB, CF8, CF8M

Disc: CF8+PTFE, CF8M+PTFE

Seat: PTFE

Connection: Wafer, Lug



PTFE Butterfly Valve

BSEN 1092, DIN 2501, ANSI, JIS, AS2129

Size: DN50~DN600

Body: Ductile Iron

Disc: CF8, CF8M

Seat: PTFE

Connection: Wafer, Lug, Flange



PTFE Butterfly Valve

BSEN 1092, DIN 2501, ANSI, JIS, AS2129

Size: DN50~DN600

Body: WCB

Disc: CF8 +PTFE, CF8 +PFA

Seat: PTFE

Connection: Wafer, Lug, Flange

APPLICATION SCENARIO



Industrial water application



Nuclear plant



Petroleum



Steel



Wastewater treatment



Acid-base



Food



Irrigation



Company Advantages



I Área de Negócios: Produtos de Controle de Fluido, Produtos de Tecnologia e Proteção Ambiental.

II Centros de usinagem CNC avançados, células de processo profissionais, equipamentos de soldagem de grande alcance, linhas de montagem automática e revestimento.

III Unidade de referência padrão da China, para participar do desenvolvimento de normas relevantes da indústria válvula.

IV Criamos um centro de pesquisa e desenvolvimento em Houston, Texas, nos Estados Unidos.

V Padrão do produto: GB, padrão alemão, padrão americano, TUV CE, ISO 9001, Adwo-2000, TS, Ped, Wrc Wras, KTW, API 6D, API609.

VI Produção principal: válvula de borboleta, válvula de esfera, válvula de portão, válvula de retenção, válvulas de globo, acessórios para tubos, manual / pneumático / atuador elétrico, peças de válvulas.

Exhibition Photos



Our Certificates



Perguntas frequentes

P: Se eu precisar de cotação, quais informações precisamos?

A: Materiais, Temperatura, Pressão, Médio, Sistema de Aplicação.

Q: Você pode fornecer atuadores, o que você tem?

A: válvulas pneumáticas, elétricas, hidráulicas, solenóides. RKSfluid Atuadores adotam a tecnologia dos EUA. Que você precisa, apenas nos diga.

Q: Qual é a sua capacidade produtiva?

R: RKSfluid tem quatro plantas que podem fornecer os produtos que você precisa.

Q: tempo de execução de produção

A: Produtos normais têm estoque em 2 ~ 5 dias úteis. Base personalizada em sua necessidade.

Q: MOQ.

A: 1 pc para todos os produtos.

P: Que tal a garantia de qualidade?

Um teste de qualidade 100% antes da entrega, garantia de 2 anos. Certifique-se de sua segurança no trabalho.

Nós temos TÜV, API, WRAs, CE, Certificação ISO.

Standard de acordo com DIN, ASME, BS EN, JIS, API, AWWA.

P: Como você poderia fornecer serviço de qualidade aos nossos clientes?

A: RKSfluid possui 20 anos de experiências e mais de 70 engenheiros de P & D fornecem suporte técnico, seleção de modelos e orientação de instalação para você.