



# RKSfluid®

A key Valve in Flow Control



Butterfly Valve



Ball Valve



Gate Valve



Globe Valve



Check Valve



Pipe Fittings

## DESIGN FEATURES

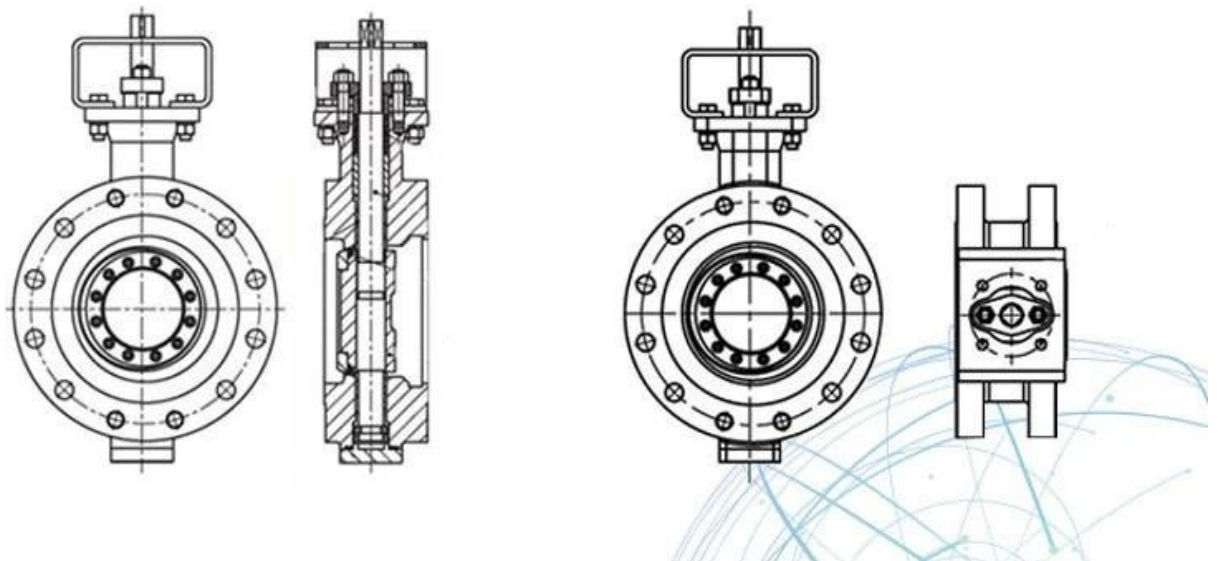

# APPLICATION SCENARIO



Industrial water application



Power plant



Petroleum



Nuclear plant



Hydroelectric power



Marine operation



Healing drugs



Refined coal



# Our Factory



# Company Advantages



I: 21 years of professional experience, 28 top senior professional researchers, 2 professional testing centers, 100% high level ex-factory inspection, 2 years quality assurance, repair and replacement, 4 factories, High quality imported materials

reference

IV

Standard 认证: GB, ISO 9001, TUV CE, ISO 9001, ADWO-2000, TS, PED, WRC WRAS, KTW, API 6D, API609

VI 设计: 展会设计, 展位设计, 宣传物料, 产品陈列, 灯光设计, 音响设计, 舞台设计 / 活动策划 / 品牌推广, 品牌传播

## Exhibition Photos





Q: RKSfluid 20 R&D 70

A: RKSfluid 20 R&D 70