



DESIGN FEATURES

DURABLE

- No-pin connection, 1 pc blow-out proof stem
- DI/CI Nodularity over 95%

ANTI-CORROSION

- Material: Epoxy powder:  , Earth Best!
- Coating Thickness: 200-250µm
- Spraying temp: over 200°C. Doesn't fade, even wipe with diethyl ether

QUALITY STANDARD

- 100% quality test, follow DIN, ASTM, JIS, GB/T, ISO, BS EN, API
- ONLY ONE Manufacturer get CE certification up to DN1800
- 2 years warranty. 15000 times On-off test, 30000 times Destructive experiment



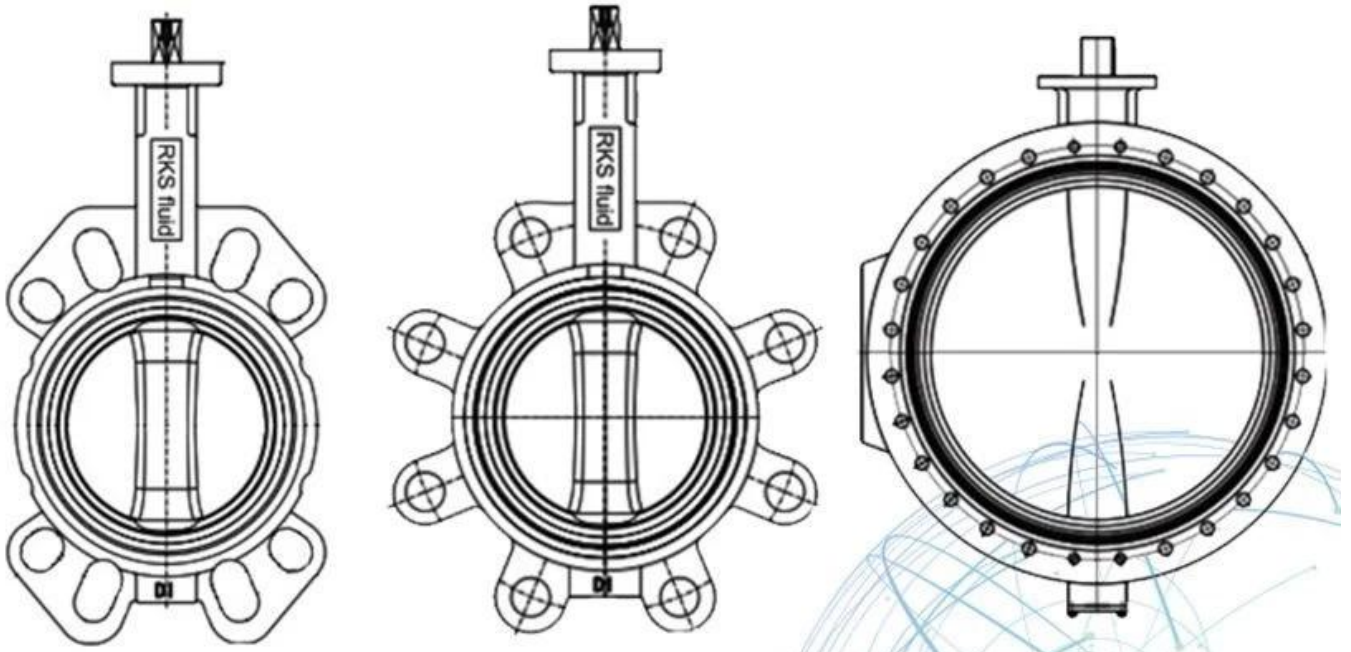

APPLICATION SCENARIO



Industrial water application



Power plant



Sea water desalination



Water treatment



Water supply and drainage



HAVC



Food and drug



Water transport



Company Advantages



i. 21 years of professional experience

ii. Independent research and development team
28 top senior professional researchers

unction 100% high level ex-factory inspection

iv. 2 professional testing centers

v. High quality imported materials: GB, TUV CE, ISO 9001,

ADWO-2000, TS, PED, WRC WRAS, KTW, API 6D, API609

VI 000000000000: 000000000000, 00000000, 0000000000, 0000000000, 000000000000, 00000000
000, 000000 / 00000000 / 00000000000000000000, 000000000000

Exhibition Photos



Our Certificates



