

**RKSfluid®**



**RKSfluid®**



**RKSfluid®**



**RKSfluid®**



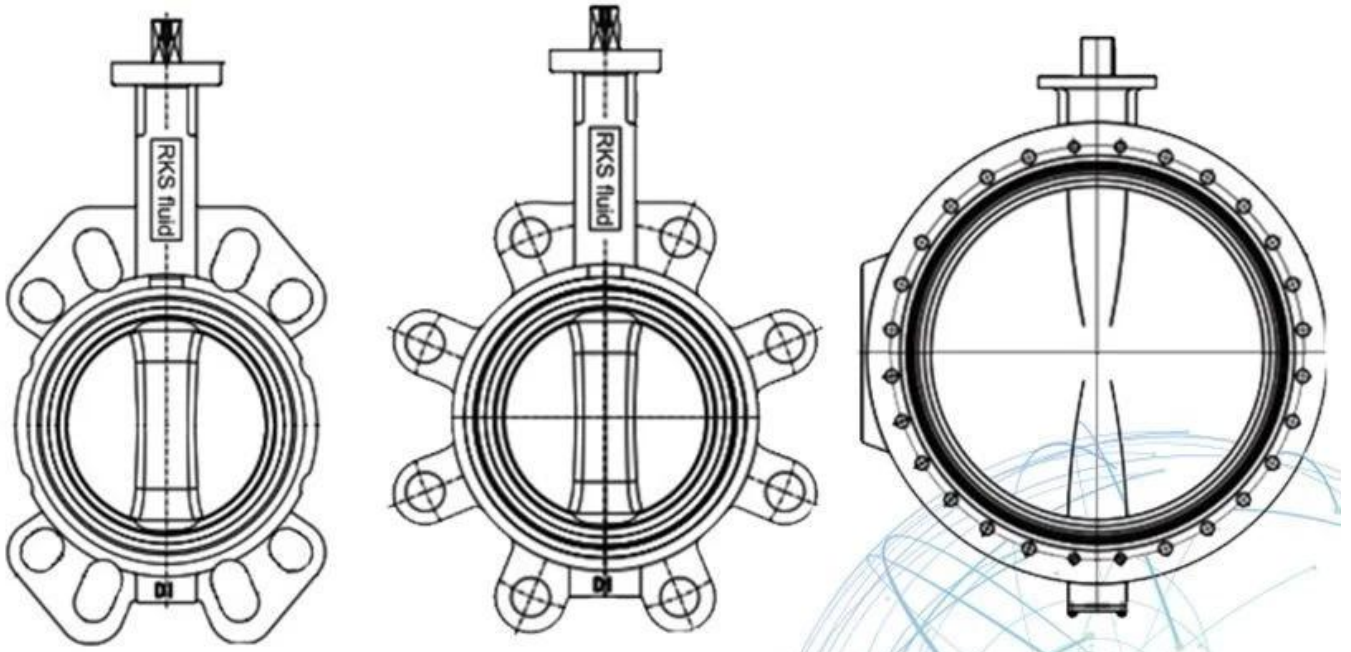

## APPLICATION SCENARIO



Industrial water application



Power plant



Sea water desalination



Water treatment



Water supply and drainage



HAVC



Food and drug



Water transport



## Our Factory



## Exhibition Photos



# Our Certificates



area :

||

reference [redacted]  
[redacted]

IV [redacted]

Standard [redacted]: GB, [redacted], [redacted], TUV CE, ISO 9001, ADWO-2000, TS, PED, WRC WRAS, KTW, API 6D, API609

VI [redacted]: [redacted], [redacted], [redacted], [redacted], [redacted], [redacted]  
[redacted], [redacted] / [redacted] / [redacted], [redacted]