

PRODUCT STRUCTURE

Features

- Size range DN100-1200mm
- Standard-ISO/ BS/DIN /AWWA/API
- Tests standard-BS EN 12266-1
- Body-Ductile Iron/Cast Iron/Stainless Steel/WCB
- Body Ring-SS420/SS304/SS316
- Disc Ring-EPDM
- Shaft-420/S5431/SS316
- Fusion bonded epoxy coating- Min 300 Microns

This series tilting check valves are suitable to be used at the exit of the pump whose medium is water. It is used to prevent or reduce medium back from water hammer. So it can protect the pipeline system. Suitable temperature $\leq 80^{\circ}\text{C}$

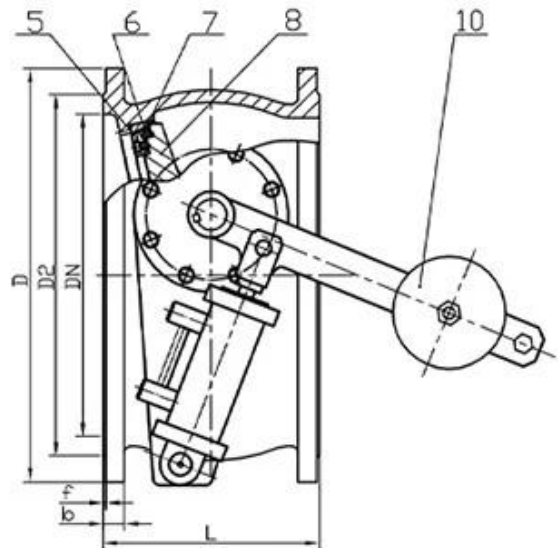
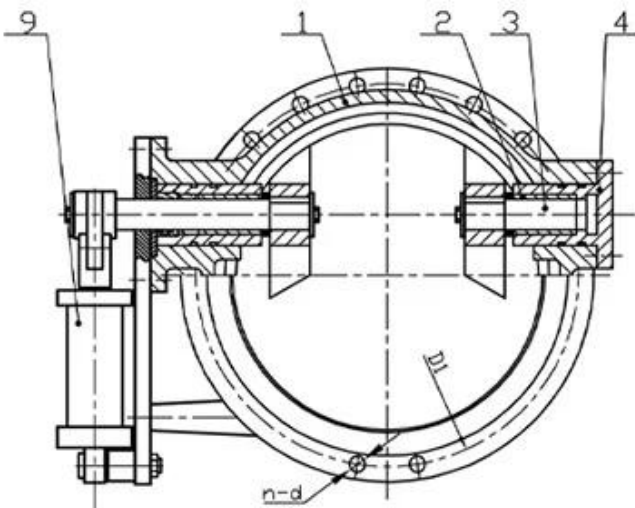

APPLICATION SCENARIO



Industrial water application



Power plant



Sea water desalination



Water treatment



Water supply and drainage



HAVC



Food and drug



Water transport



COMPANY FACTORY



COMPANY INFORMATION



I 公司宗旨： 秉承“以人为本、诚信至上、服务至上”的经营理念，为客户提供最优质的产品和服务。

II 公司优势： 拥有先进的生产设备和专业的技术团队，产品质量稳定可靠，交货周期短，售后服务周到。

III 公司资质： 拥有 ISO 9001 质量管理体系认证，产品符合 GB、TUV CE、ISO 9001 等国际标准。

IV 公司服务： 提供全方位的技术支持和售后服务，确保客户满意。

V 公司认证： GB, TUV CE, ISO 9001, ADWO-2000, TS, PED, WRC WRAS, KTW, API 6D, API609

VI 公司合作： 与国内外知名企业合作，共同开拓市场，实现共赢。

01

21 years of professional experience

03

Independent research and development team
28 top senior professional researchers

05

100% high level ex-factory inspection

07

2 years quality assurance, repair and replacement

4 factories

02

2 professional testing centers

04

High quality imported materials

06

COMPANY QUALIFICATION



COMPANY EXHIBITION



Partners



Q: RKSfluid 20 R&D 70

A: RKSfluid 20 R&D 70