



# RKSfluid®

A key Valve in Flow Control



Butterfly Valve



Ball Valve



Gate Valve



Globe Valve



Check Valve



Pipe Fittings

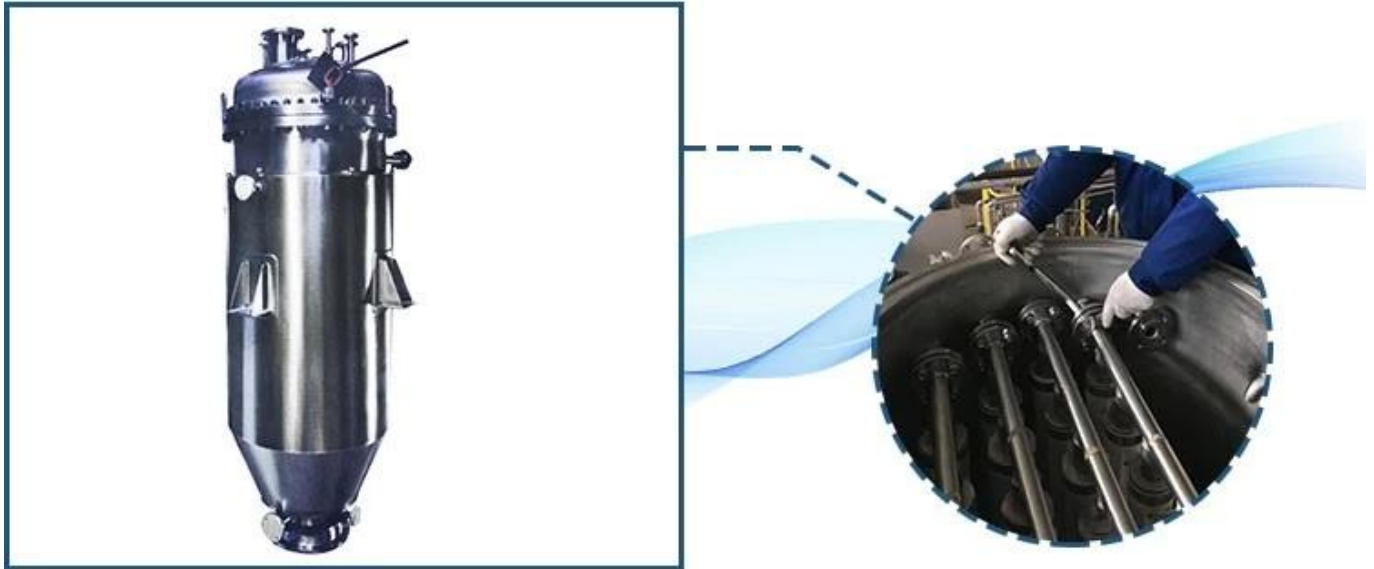

- Intelligent system, fully automatic sealing operation
- Seal zero leakage, unique structure easy for back flushing
- High efficiency by purified gas back washing
- High impurity content of filtration 0.1% ~ 50%
- Removable, porous wick, easy to replace, clean and maintain
- Designed for high production standard. Such as non-polluting food, biological products, medicine, fine chemistry, etc.

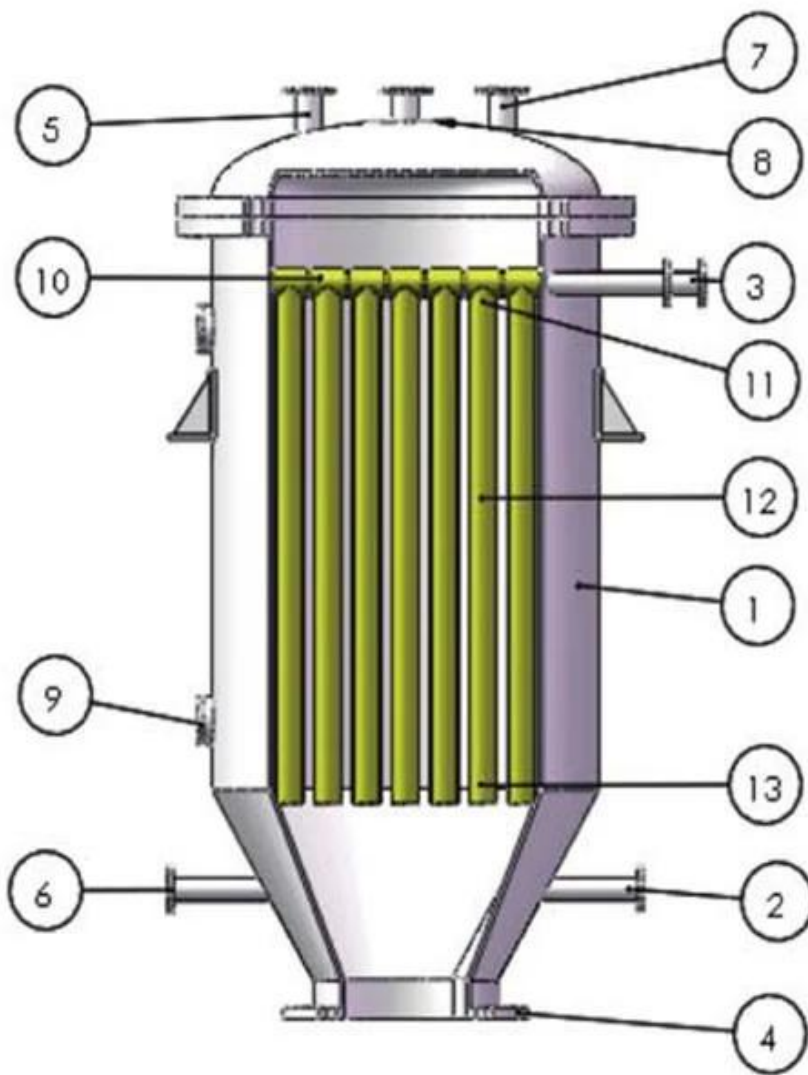

- 1, Pressure Vessel
- 2, Outlet
- 3, Outlet of clear liquid
- 4, Deslagging Port
- 5, Vent & Overflow port
- 6, Feed port
- 7, Connection port of instruments
- 8, Standby Port
- 9, Viewport
- 10, Liquid collection tube
- 11, Filtration unit
- 12, Filtration medium
- 13, Clamp for fixed the filter element

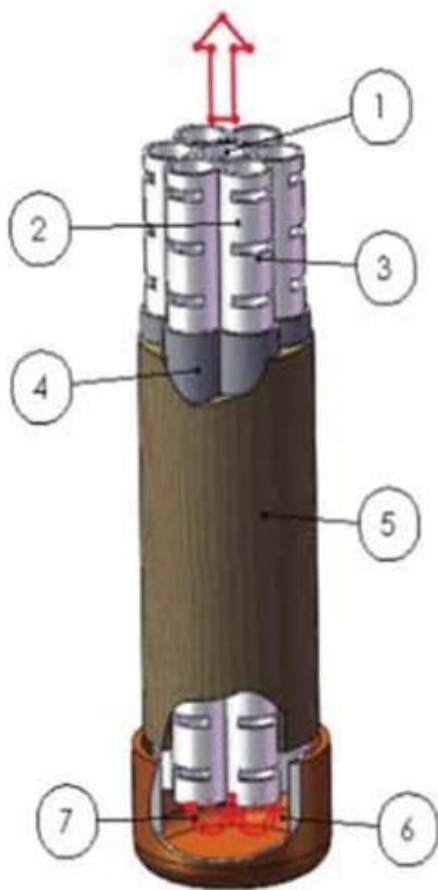

1. Central tube & Clear liquid collection tube
2. Filtration tube
3. A hole of filtration tube
4. Filtration medium
5. Filter cake
6. Collection chamber (connect the centre tube and filtration tube)
7. Clear liquid
8. Backflush gas

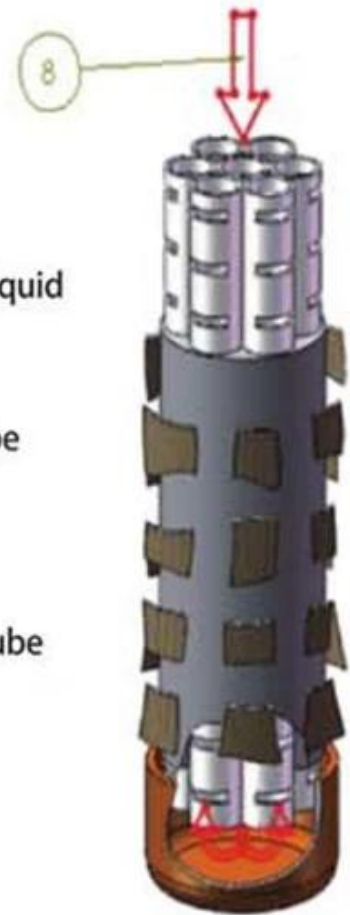

## Our Factory



## Company Advantages

01

21 years of professional experience

03

Independent research and development team  
28 top senior professional researchers

05

100% high level ex-factory inspection

07

2 years quality assurance, repair and replacement

4 factories

02

2 professional testing centers

04

High quality imported materials

06



1. 本公司拥有先进的生产设备，采用优质材料，严格按照国际标准进行生产，确保产品质量。我们拥有完善的质量管理体系，通过了 ISO9001 认证。我们的产品广泛应用于市政、工业、农业等领域。
2. 我们拥有完善的质量管理体系，通过了 ISO9001 认证。我们的产品广泛应用于市政、工业、农业等领域。
3. 我们的产品符合 API, AWWA, ASME, BS EN, DIN, JIS, TUV, CE, ISO9001, TS, OHSAS, WRAS 等国际标准。
4. 我们拥有完善的质量管理体系，通过了 ISO9001 认证。我们的产品广泛应用于市政、工业、农业等领域。



