

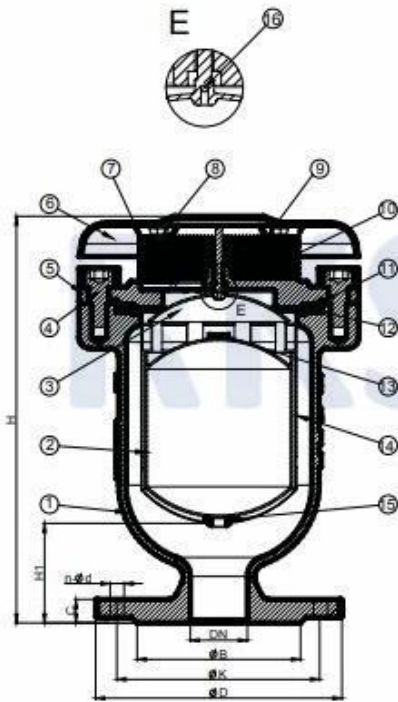

5.   BS EN 1074-4  
 Main Valve-DN50-DN300



Parts List

No.	Part Name	Material	Standard
1	Body	Ductile Iron	EN GJS 500-7
2	Float	Stainless Steel	AISI 304
3	Sealing Arc	Stainless Steel	AISI 304
4	In Hex Bolt	Carbon Steen/ Stainless Steel	G. I/ AISI 304
5	Bonnet	Ductile Iron	EN GJS 500-7
6	Cover	Carbon Steel	AISI 304
7	Screen	Stainless Steel	AISI 304
8	Hex Bolt	Carbon Steen/ Stainless Steel	G. I/ AISI 304
9	Washer	Stainless Steel	AISI 304
*10	Pillar	Aluminum	Commercial
11	O-ring	Rubber	NBR/EPDM
12	Seat	Rubber	NBR/EPDM
13	Nozzle Seat	Rubber	NBR/EPDM
14	Guide Barrel	Stainless Steel	AISI 304
15	Buffer	Rubber	NBR/EPDM
16	Small Nozzle	Stainless Steel	AISI 304

\*: For Size ≤DN150.